



Catalogue
FOOD SERVICE
Chapter
DISHWASHING

Specific model
CCO-180 R ECO 380-415V 3N 50Hz

19048591

12/06/2024

DENOMINATION:

Modular rack conveyor 180 racks/hour with entrance from the right gas heated

DESCRIPTION :

"-The Concept modular dishwashers are composed of different modules put together, which carry out different operations, making up the washing process.

- All the main parts are manufactured in AISI-304 anti-corrosion stainless steel: tanks, washing and rinsing arms, rinsing jets, doors, basket conveyance system, boiler and metal tubes.
 - Upwards-opening double panel door.
 - Tank tray filters made of AISI-304 stainless steel, easy to access and remove for cleaning and access to the tank.
 - Safety filter for pump suction.
 - Rinsing boiler with heat insulation.
 - Easy access for installation. Electrovalve located on one side (no need to remove panels to connect the machine).
 - Electrical panel designed for easy connection of dosers for liquid and solid detergents, rinse aid, limit switches, supplementary emergency stop button.
 - Washing arms easily removable as a set, for cleaning, with a plug on each branch providing access for cleaning inside.
 - Rinse jets easily dismountable and removable.
 - System of electronic regulation of speeds by means of frequency shifter.
 - Configurable electronic temperature control:
 - Wash (50 - 65 °C)
 - Rinse (70 - 85 °C)
 - Guarantor of rinse at 85 °C.
 - Pressure regulator for flow control.
 - Emergency stop button incorporated.
 - Extra anti-entrapment protection system at the entrance, mounted on the AS-260 splash guard supplement (optional).
 - Open door blocking system.
 - IPX4 protection system.
 - System for detection of blockage of conveyor carriage and automatic reverse function.
 - Energy-saving system: reduces consumption by halting operation of the pumps, and by passing the heating of the rinse to stand-by mode (70 °C).
 - Auto-timer which deactivates the conveyor motor after a pre-set period of inactivity (10 minutes)."
 - "- The ECO version conveyor dishwashers are fitted with an external hot water generator, gas heated, model GWB-40 (*).
 - The generator replaces the electric rinse boiler in the dishwasher, bringing a significant saving in electricity consumption.
 - Given the heating power of the generator, the dishwasher can be installed in facilities with a cold water connection.
 - The dishwasher has a motor pump to send the water from the generator to the rinse jets."
 - AS-260 splash guard supplement.
 - High-power washing system with 5 upper and 5 lower washing branches.
 - Rinse and pre-rinse, both double effect.
 - 3 programs 90, 135 and 180 baskets/hour.
- Entry through the right part of the machine.

POSSIBLE OPTIONS :

DIMENSIONS



X Width	1760 mm	X Gross width	1850 mm
Y Depth	790 mm	Y Gross depth	955 mm
Z Height	1560 mm	Z Gross height	1950 mm
Net Weight	259,0 kg	Gross Weight	382,0 kg
Net volume	2,529 m3	Gross volume	3,445 m3

ELECTRICITY TECHNICAL SPECIFICATIONS

Electric power	19,900 kW
Voltage	380-415V
Phases	3N
Electric frequency	50Hz
Amperage (A)	32,9
Engine power	2,20 kW
Heating power	17,00 kW

WATER TECHNICAL SPECIFICATIONS

Pressure	H2O: 200-400kPa(2-4bar)
Water max consumption	210,00 L/h
Maximum Temperature	Water Inlet Max Temp:60°C

COLD TECHNICAL SPECIFICATIONS

Noise level	72,00 dB
-------------	----------

CONNECTIONS TECHNICAL SPECIFICATIONS

230 V three-phase wiring	3X50+T - 160 A
Three-phase +N 400V wiring	4X6+T - 40 A
Drain 1 diameter	38





Catalogue
FOOD SERVICE
Chapter
DISHWASHING

Specific model
CCO-180 R ECO 380-415V 3N 50Hz

19048591

12/06/2024

- Electric transformation to 230V three-phase without neutral (230V 3 ~)
- Electric transformation to marine version (440V 3~ 60 Hz.)
- Gas water booster 50Hz
- Gas water booster 50Hz
- Drying tunnel
- Anti-splash guard supplement (exit)

POSSIBLE ACCESSORIES :

- BASKETS
- BASKETS FOR DISHWASHERS
- BASKETS FOR GLASSES
- MODULAR ELEMENTS
- TABLES FOR RACK TYPE DISHWASH.
- GAS WATER BOOSTER

SUPPLIED ACCESSORIES:

- 19000487 Basket for 16-18 plates, 500x500x110 mm. 2
- 19036306 Standard basket with dense base 1



Catalogue
FOOD SERVICE
Chapter
DISHWASHING

Specific model
CCO-180 R ECO 380-415V 3N 50Hz

19048591

12/06/2024

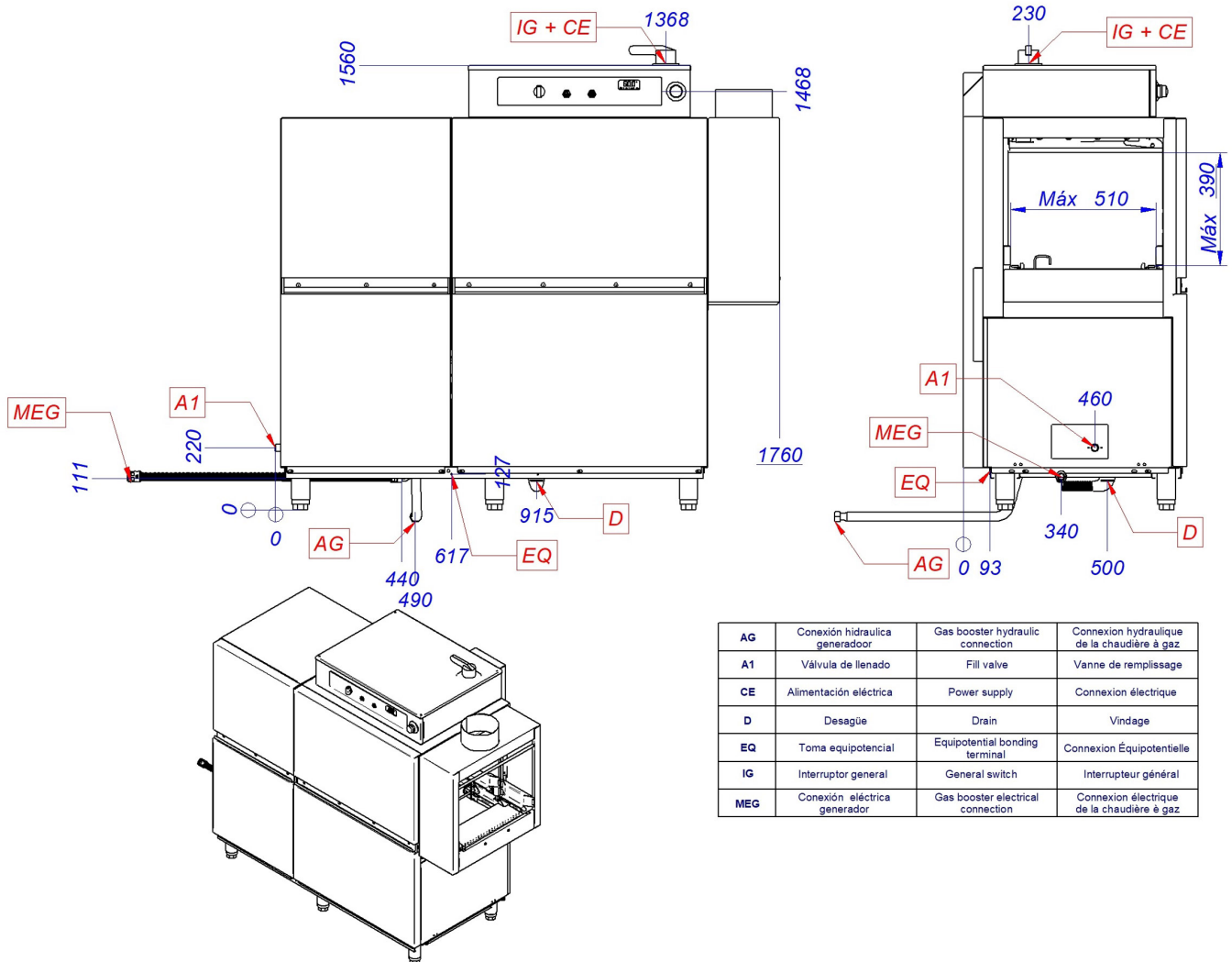

AG	Conexión hidráulica generador	Gas booster hydraulic connection	Connexion hydraulique de la chaudière à gaz
A1	Válvula de llenado	Fill valve	Vanne de remplissage
CE	Alimentación eléctrica	Power supply	Connexion électrique
D	Desagüe	Drain	Vindage
EQ	Toma equipotencial	Equipotential bonding terminal	Connexion Equipotentielle
IG	Interruptor general	General switch	Interrupteur général
MEG	Conexión eléctrica generador	Gas booster electrical connection	Connexion électrique de la chaudière à gaz