



Catalogue
FOOD SERVICE
Chapter
DISHWASHING

Specific model
COP-404 220-240V 1N 50Hz

19073733

11/06/2024

DENOMINATION:

Glasswasher with electronic control for 400 mm basket and rinse pump

DESCRIPTION :

- Front-loading glass washers - EVO Generation.
- Constructed in stainless steel.
- Door with double wall.
- Double rotating wash and rinse system, top and bottom, in stainless steel.
- Rounded tank to facilitate washing and drainage.
- Stainless steel armoured heating elements in the wash tank and rinse boiler.
- Thermostatic control of temperatures (wash, 60°C, and rinse, 85°C).
- Safety thermostat
- Rinse aid doser incorporated.
- Fitted with non-return valve.
- 260 W wash pump
- Water consumption per 2.2 litre cycle.
- Magnetic safety stop switch in door opening.
- IPX4 anti-humidity protection.
- Model with electronic control and display of temperature, functions and errors.
- Electronic programmer with help system for technical service.
- Rinse pump which guarantees a perfect hygiene result with complete linear rinse cycle at 85°C. (EFFIRINSE) de acuerdo con las especificaciones de seguridad e higiene de la norma DIN10512.
- Air Brake check valve system AA according to EN 1717/WRAS.
- Model for 400 x 400 mm baskets.
- 90s - 120s - 180s wash cycles and maximum production of 40 baskets/hour.
- Useful internal height of 270 mm.
- Tank with volume of 15 litres, with 2 kW heating element.
- Boiler with volume of 4 litres, with 2.8 kW heating element.
- Rinse pump - 150 W

POSSIBLE ACCESSORIES :

- BASKETS FOR DISHWASHERS
- BASKETS FOR GLASSES
- WATER SOFTENERS
- STANDS EVO
- VARIOUS KITS EVO
- STANDS

SUPPLIED ACCESSORIES:

- 19000792 Cutlery basket for 15 pieces of cutlery, 105x105x130 mm. 1
- 19082432 Glass basket, 400x400x110 mm. 2
- 19084452 Insert for 11 plates, 400x400x110 mm. 1

DIMENSIONS

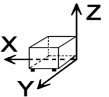

X Width	470 mm	X Gross width	530 mm
Y Depth	525 mm	Y Gross depth	680 mm
Z Height	720 mm	Z Gross height	890 mm
Net Weight	35,0 kg	Gross Weight	42,0 kg
Net volume	0,176 m3	Gross volume	0,321 m3

ELECTRICITY TECHNICAL SPECIFICATIONS

Engine power	0,26 kW
Electric power	3,060 kW
Amperage (A)	13,3
Heating power	2,80 kW
Voltage	220-240V - 1N
Electric frequency	50Hz

WATER TECHNICAL SPECIFICATIONS

Pressure	H2O: 100-400kPa (1-4bar)
Water max consumption	50,00 L/h
Maximum Temperature	Water Inlet Max Temp:60°C

CONNECTIONS TECHNICAL SPECIFICATIONS

Single-phase 230V wiring	2X2,5+T - 20 A
Drain 1 diameter	2"

OTHERS

Noise level	62,00 dB
-------------	----------



Catalogue
FOOD SERVICE
Chapter
DISHWASHING

Specific model
COP-404 220-240V 1N 50Hz

19073733

11/06/2024

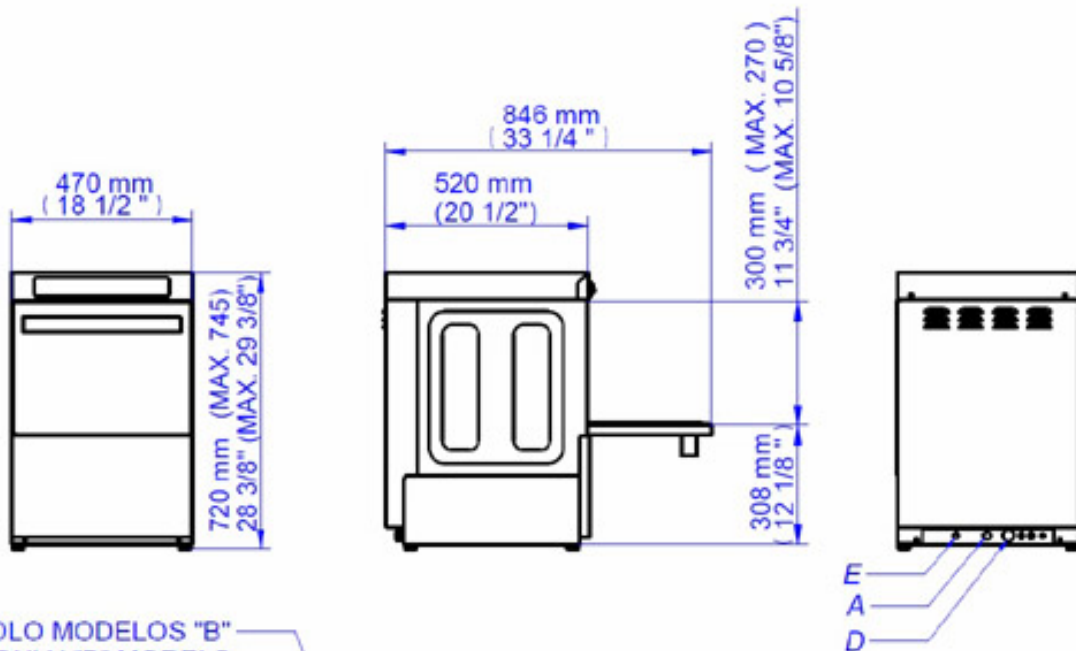

SOLO MODELOS "B"
ONLY "B" MODELS
SEULEMENT MODÈLES "B"

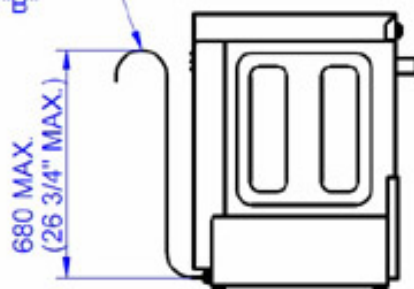

A: ENTRADA DE AGUA
E: ALIMENTACIÓN ELÉCTRICA
D: DESAGÜE

A: WATER INLET
E: ELECTRICAL CONNECTION
D: DRAIN

A: ARRIVÉE D'EAU
E: CONNEXION ÉLECTRIQUE
D: VIDANGE