

QUICK IT

Product Manual

Installation, use and maintenance



INDEX

1. GENERAL SAFETY AND ACCIDENT PREVENTION RULES	4
1.1. Personnel in charge of the use of the equipment.....	4
1.2. Electrical hazard.....	4
1.3. Thermal hazard	4
1.4. Danger of corrosion	5
2. INTRODUCTION	6
3. TECHNICAL CHARACTERISTICS	7
3.1. Main features of the Mychef QUICK 1T	7
4. RECEPTION, TRANSPORT AND LOCATION	8
4.1. Reception	8
4.2. Transport	8
4.3. Positioning.....	9
5. INSTALLATION	12
5.1. Electrical connection.....	12
5.1.1. Single-phase connection 230V L+N.....	13
5.2. Catalytic filter installation.....	13
6. INITIAL CONFIGURATION	15
6.1. Mychef QUICK 1T start up.....	15
6.2. Mychef QUICK 1T configuration.....	16
6.2.1. Date/Time	17
6.2.2. Language	18
6.2.3. Sound	19
6.2.4. Temperatures.....	20
6.2.5. System	21
6.2.6. Restore factory defaults	23
6.2.7. Accounts	24
6.2.8. USB	25
6.2.9. Metric system	27
6.2.10. Consumption	28
6.2.11. Errors and alarms	29
6.3. Mychef Cloud linkage	29
6.3.1. Setting up Wi-Fi connection	31
6.3.2. Add device in Mychef Cloud.....	32
6.3.3. Check correct linkage	33

7. USE	34
7.1. Switching on the equipment.....	34
7.1.1. First use	34
7.2. Main menu.....	35
7.2.1. Cooking.....	37
7.2.2. Routine Scheduler	40
7.2.3. Save Recipes.....	41
7.3. Cooking	46
7.3.1. Cooking a recipe	46
7.3.2. Cooking MultiCook recipes.....	47
7.3.3. Recipe information	48
7.4. MyCare.....	49
8. MAINTENANCE	50
8.1. Cleaning	50
8.1.1. Suction and door gasket.....	51
8.1.1.1. Aspiration.....	51
8.1.1.2. Door gasket	52
8.1.2. Outer casing	53
8.1.3. Control panel	54
8.1.4. Accessories	54
8.2. Preventive maintenance	54

1. GENERAL SAFETY AND ACCIDENT PREVENTION RULES

1.1. Personnel in charge of the use of the equipment

The appliance can be used by children aged 8 years and above and by persons with reduced physical, sensory, or mental capabilities or lack of experience and knowledge, only if they have received supervision or instruction concerning the hazards involved. Children must not play with the appliance. Cleaning and maintenance work is the responsibility of the user and must not be carried out by children without supervision.



Personnel performing any action on the oven, whether it be use, cleaning, installation, handling, etc., must be aware of the safety regulations and operating instructions.



Do not allow unauthorized personnel to use, handle or clean the equipment.

1.2. Electrical hazard

Work on the electrical power supply and access to live parts may only be carried out by qualified personnel under their own responsibility. In any case, such access must be carried out with the equipment disconnected from the mains.

If the appliance is placed on a trolley or on tables that are mobile, do not allow it to move while it is connected to the power supply in order to avoid possible damage to the wiring, drain pipes or water inlet pipes. If the appliance is to be moved or repositioned, the cables must be disconnected.

1.3. Thermal hazard

When the appliance is in operation, the door must be opened slowly and carefully to avoid possible burns from steam or hot air escaping from inside the cooking chamber.

Accident hazard. Take care when using food pans in the oven when the top shelf is 160 cm or more. There is a risk of injury from the hot contents of the trays.



Keep ventilation openings free of obstructions. Do not install the equipment in the vicinity of flammable products. Avoid positioning the oven near heat sources such as hobs, griddles, fryers, etc.

Check the safety distances in section Positioning.



DANGER OF ACCIDENT! Take care when using food containers in the oven when the upper shelf is 160 cm or higher. There is a risk of injury from the hot contents of the trays.



While the oven is in operation, avoid touching metal parts and the door glass, as they can exceed 60°C. Touch only the handle and the control panel.

1.4. Danger of corrosion

When using cleaning products, special care and appropriate safety measures should be taken when handling these products. Always read the safety data sheet of the different chemical products before use and follow the instructions for use. These products in contact with any part of the body are abrasive and can cause skin and eye irritations and caustications.

2. INTRODUCTION

This manual has been carefully prepared and revised in order to provide reliable information and assistance for correct installation, use and maintenance that will ensure proper operation and prolong the life of the oven. This manual is divided into 3 parts, the first part dedicated to the installation of the equipment at the working point, the second part to the use and the third part focused on the cleaning and maintenance of the oven.



Before carrying out any intervention or use of the equipment, it is necessary to read this manual carefully and completely.

The manufacturer declines all implicit or explicit responsibility for any errors or omissions it may contain.

- The oven must not be used by personnel who have not received any training, skills or experience necessary for the correct operation of the equipment. Do not allow children to use or play with the equipment.
- The owner of the equipment is obliged to have this manual read by the personnel in charge of its use and maintenance, as well as to keep this manual in a safe place so that it can be used by all users of the equipment and for future reference. If the equipment is sold to other persons, this manual must be handed over to them.
- This oven must only be used for its intended purpose, i.e., cooking, heating, regenerating or dehydrating food. Any other use may be dangerous and may result in personal injury and damage to property.
- The equipment is shipped from the factory once it has been calibrated and passed rigorous quality and safety tests to ensure its correct operation.



The manufacturer shall disclaim any liability for problems caused by improper installation, modification, misuse, or improper maintenance.

3. TECHNICAL CHARACTERISTICS

3.1. Main features of the Mychef QUICK 1T

	QUICK 1T
External measurements (W x H x D)	397 x 410 x 629 mm
Capacity	31 x 31 x 18 cm
Servings/Hour	20

Table 1. Main characteristics of Mychef QUICK 1T ovens

The A-weighted sound pressure level of Mychef ovens is less than 70dB (A).

4. RECEPTION, TRANSPORT AND LOCATION

Before installation, the dimensions of the site where the equipment is to be located and the electrical connections must be verified.

4.1. Reception

Once the oven has been received, check that the model purchased corresponds to the order.

Check that the packaging has not been damaged during transport and that no parts of the equipment are missing. If you detect any anomaly or problem, contact your distributor immediately.

4.2. Transport

The equipment should be transported in its original packaging to the location closest to the point of installation to avoid damage as much as possible. It is recommended to keep the original packaging until the equipment is properly installed and operational.

When moving the equipment and placing it in its workspace, the following remarks should be taken into account:

- The dimensions of the different models to pass through narrow places (corridors, doors, narrow spaces). See chapter 3.
- Handling must be carried out by the personnel necessary to move the load of the furniture, taking into account the current occupational safety regulations at the place of installation.
- During transport, the oven must always be in an upright position. It must be lifted perpendicular to the floor and transported parallel to the floor.
- Make sure that it does not tip over during transport and that it does not hit any objects.

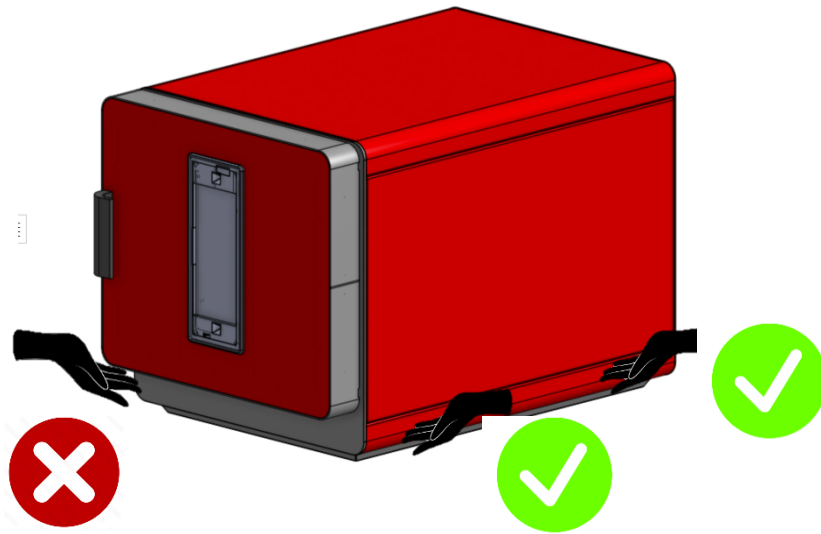

Figure 1. Oven handling



The oven must never be held by the door.

4.3. Positioning

- Place the oven at a convenient distance from the wall so that electrical connections can be made. There must be a minimum distance between the oven parts so that it can ventilate and cool properly. This minimum distance is:
 - o 50mm on the left and right sides
 - o 50mm at the rear
 - o 50mm at the top
- If there are sources of heat or steam near the equipment (stove, grill, griddle, fryer, pasta cooker, kettle, tilting frying pan, etc.), these must be at a distance of more than 1 metre.
- Check that the oven is not exposed to hot air or fumes in the areas where the cooling fans are located.

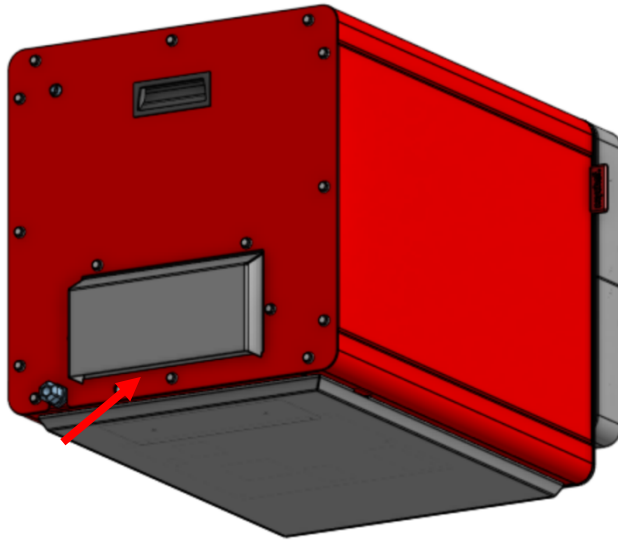

Figure 2. Cooling zone



Under no circumstances obstruct the breathing zones or place any element that could hinder the air intake. Do not place any heat source that could heat up the cooling air.

- Once it is in place in the workspace, check that it is level.

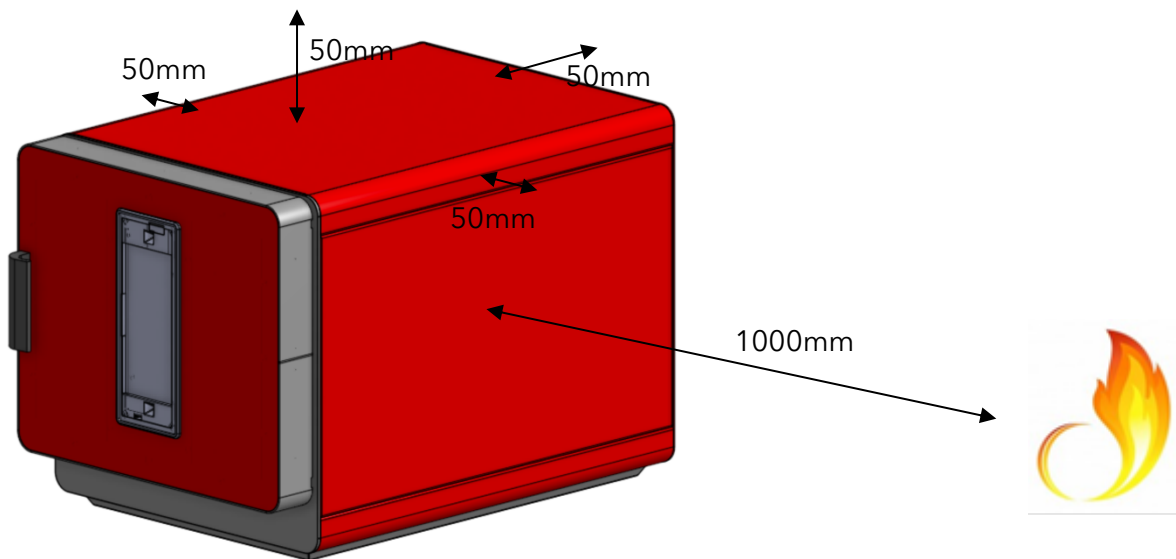

Figure 3. Safety distance



Be extremely careful with the cooling zones of the oven. If it draws in fumes or hot air, this can drastically reduce the life span of the components.



For the installation of stacked Mychef ovens, please follow the instructions supplied with the stacking kit.

Under no circumstances should breathing zones be obstructed or anything that could hinder aspiration be placed.

5. INSTALLATION

5.1. Electrical connection

Check that the voltage at the point where the oven is to be connected coincides with the operating voltage of the equipment.

The following table indicates the electrical characteristics of each of the devices:

	Voltage	Power (kW)	Current (A)	Cable cross-section (mm ²)
QUICK 1T EU	230/L/50-60	3.6	16	2,50
QUICK 1T UK	230/L/50-60	2.9	13	2,50

Table 2. Electrical connection characteristics

Before carrying out any electrical work, make sure that there is no electrical current at the connection point of the equipment.

The equipment must be connected to the mains via an all-pole switch with a contact opening distance of more than 3mm. Also install a class A differential device and overcurrent protection.

Always ensure effective grounding.

Connect the device to an equipotential bonding system  using the contact specially provided for this purpose (see equipotential bonding sign on the bottom left side of the device). If two devices are stacked, both devices must be connected to the equipotential bonding system.



Connection to an equipotential bonding system ensures additional safety in the event of simultaneous earth leakage and differential failure.

The wiring and other safety devices used for the electrical installation must have the appropriate cross-section for the equipment in question.



Always comply with the applicable regulations for connecting the equipment to the low-voltage mains.

Before starting the electrical installation, check that the electrical requirements of the oven and the mains supply are the same.



Never connect a phase to neutral or earth. Check that the voltages of the installation correspond to those of the equipment.

The following sub-chapters show the possible connection types for Mychef ovens. The voltage of each oven can be found on the oven identification sticker.

5.1.1. Single-phase connection 230V L+N

Colour		Cable
■	Brown	L1
■	Blue	Neutral
■	Green-yellow	Grounding

Table 3. Single-phase cable 230V L+N

5.2. Catalytic filter installation

If the catalytic filter accessory has been purchased, the following instructions for correct installation shall be followed:

- Unscrew the screws holding the plates on the sides of the chamber so that they can be removed.
- Unscrew the screws holding the turbine protection plate.
- Remove the turbine protection plate and screw on the filter holder with two screws.
- Insert the protection plate at an angle (Figure 5) into the chamber and place the filter in the filter holder.
- Put each plate back in place with the corresponding screws.

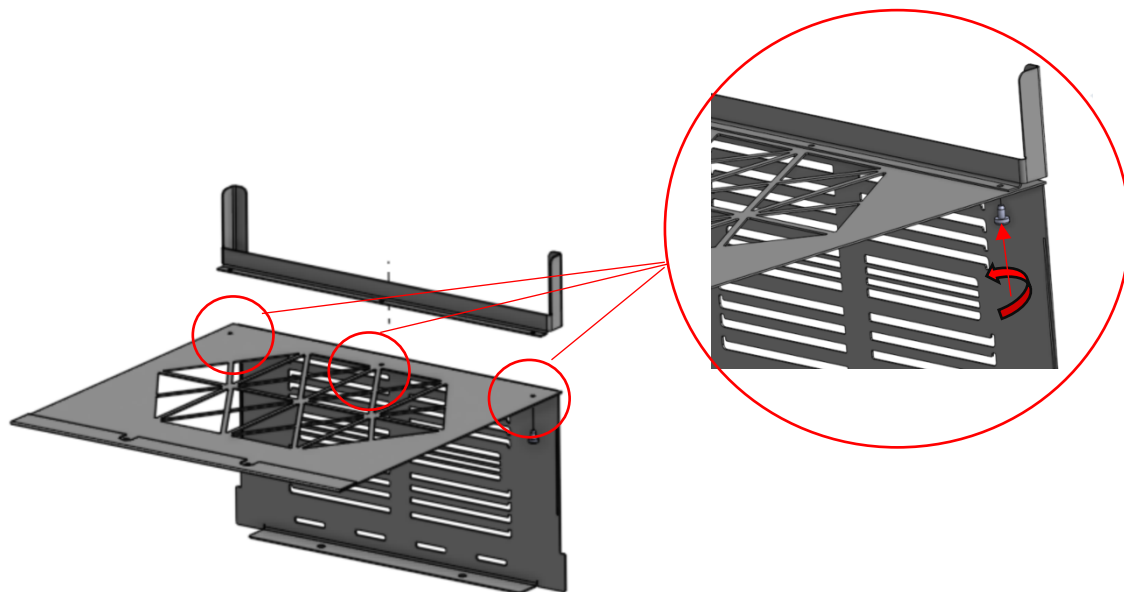

Figure 4. Mounting the filter holder to the protection plate

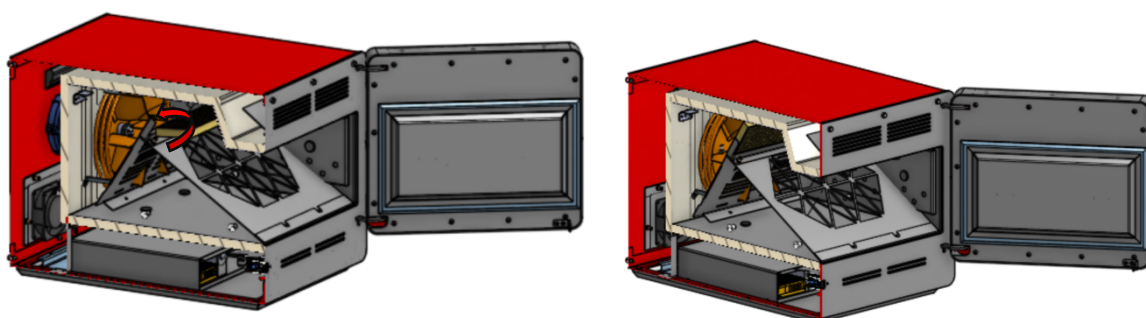

Figure 5. Filter placement



In order to remove the protection plate, the catalytic filter must first be removed, by carrying out the operation inside the chamber.



Make sure you have performed a CoolDown completely to handle the plates.



The catalytic filter is an accessory. Everything not required for installation is included in the filter installation kit.

6. INITIAL CONFIGURATION

6.1. Mychef QUICK 1T start up

This short instruction is intended to explain the steps to follow to start the Mychef QUICK 1T oven for the first time.

Switch on the oven. Then the main menu will appear where you can configure the device.



Figure 6. Main menu

6.2. Mychef QUICK 1T configuration

Once the configuration section has been selected, the following menu appears where the different oven parameters can be configured. This section describes the operations necessary for the correct configuration of the Mychef oven. Some of the functions have access rights, so it will only be possible to access them by entering a password. The oven configuration can always be modified from the main menu.

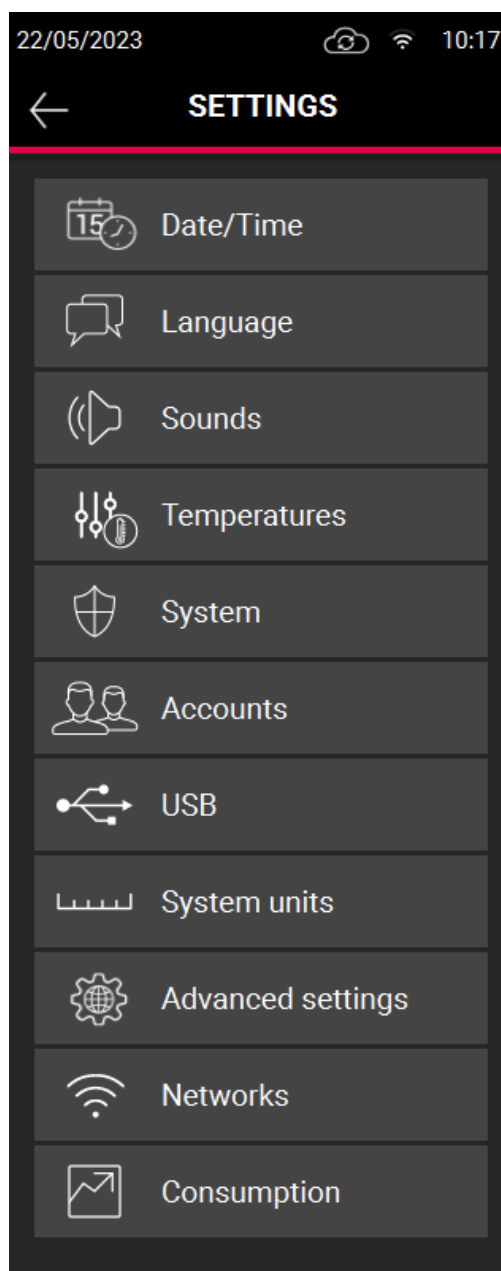

Figure 7. Configuration menu

6.2.1. Date/Time

To set the date and time, press or select the buttons and adjust. To exit, press the back arrow and the settings will be saved.

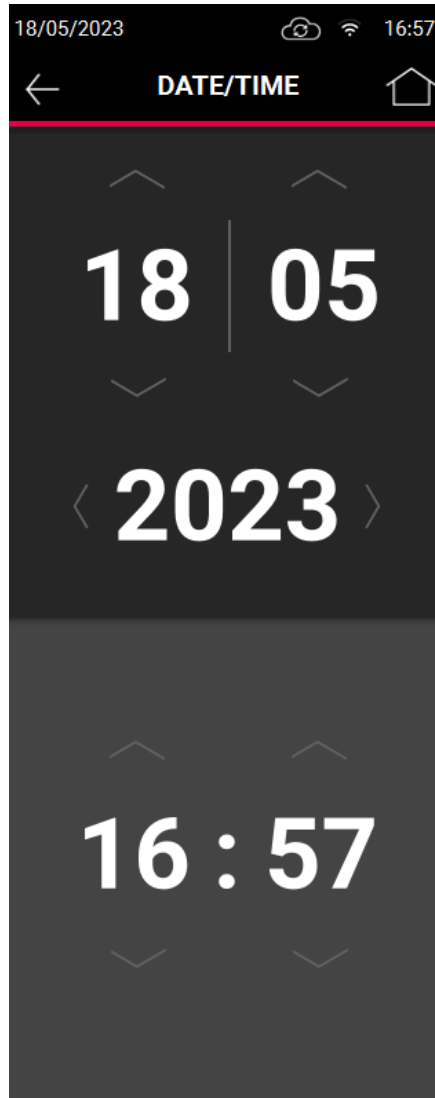

Figure 8. Date/time settings

6.2.2. Language

To change the language, simply select the desired language. To exit, press the back arrow and the configuration will be saved.

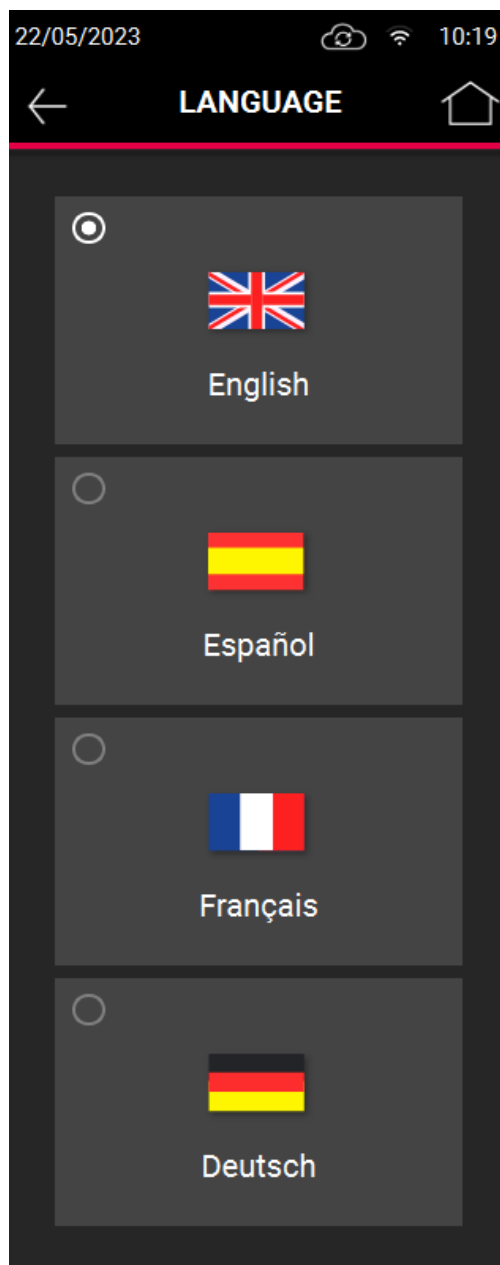

Figure 9. Language settings

6.2.3. Sound

The sound setting allows you to select between different warning tones. These warning tones correspond to the acoustic signals emitted by the oven when certain functions are performed. For example, the end of cooking or an alarm. The setting also allows you to change the volume of the tone and mute the sound.

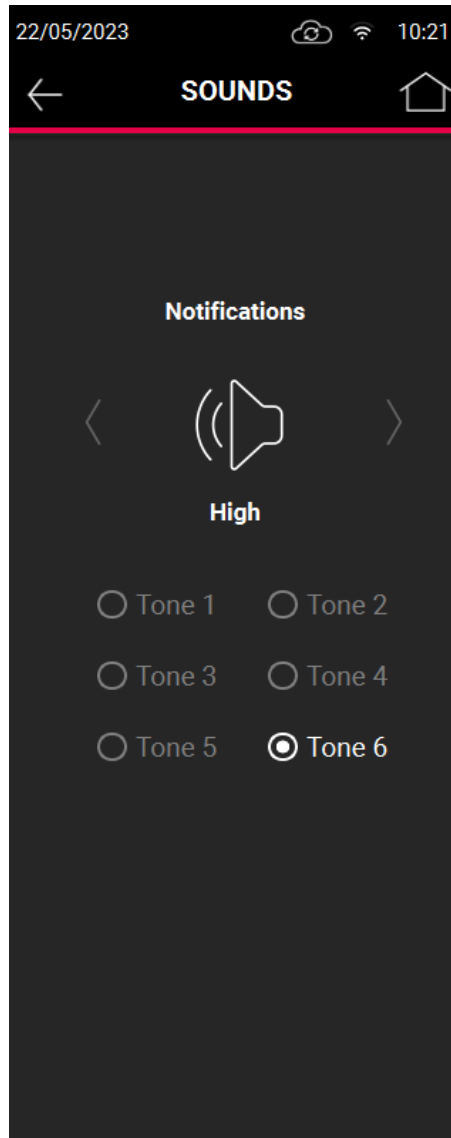

Figure 10. Sound configuration

6.2.4. Temperatures

Once the temperature has been selected and preheating has been carried out, the oven maintains the selected temperature, with the fan active at low speed, so that it is ready for cooking at any time.

It is possible to store up to a maximum of 6 temperatures in the oven, together with a label to identify it. The selected temperatures are displayed in the temperature menu (Figure 21).

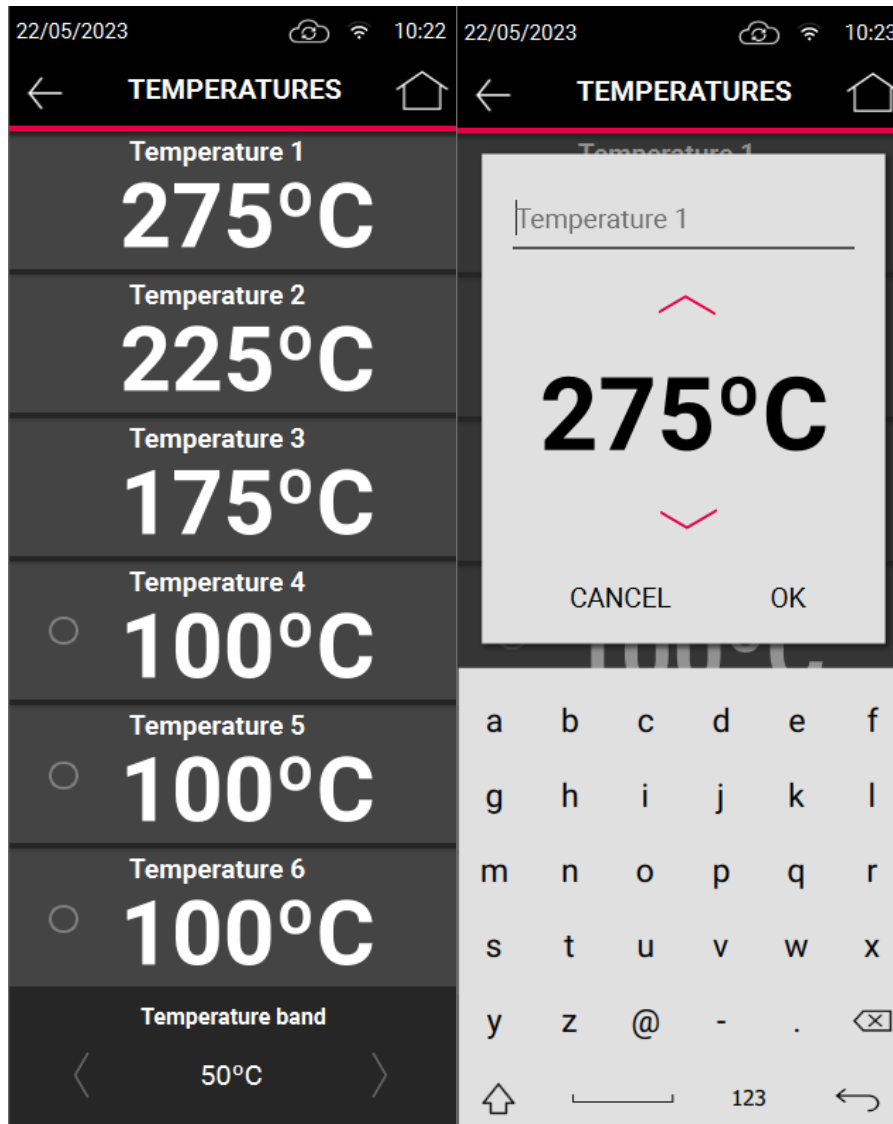

Figure 11. Temperature setting

The temperature band option allows the oven to work with a margin of $\pm 50^{\circ}\text{C}$ (default) to speed up the preheating or cooling process of the chamber so that recipes with different temperatures can be compatible. The temperature band parameter can be modified in increments of 10°C between 0°C - 50°C .

6.2.5. System

System displays the software version of the equipment and the option to upgrade or restore the system to factory defaults.

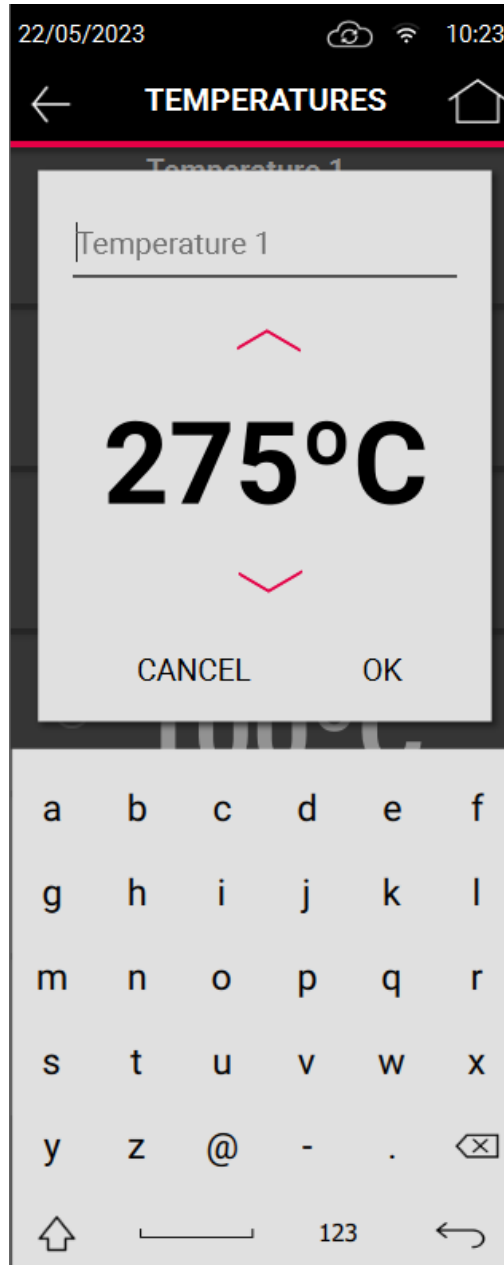

Figure 12. System information

To perform a software update it is necessary to click on the Update button. Software updates will be available on the Mychef website. The installation must be done via Wi-Fi or a USB device with a FAT32 file system.

The oven will then restart and display a confirmation message whether the oven has been updated successfully or not.

In case the update was not successful, check the internet connection, the USB file system (FAT32) and the update file, which must be a higher version.

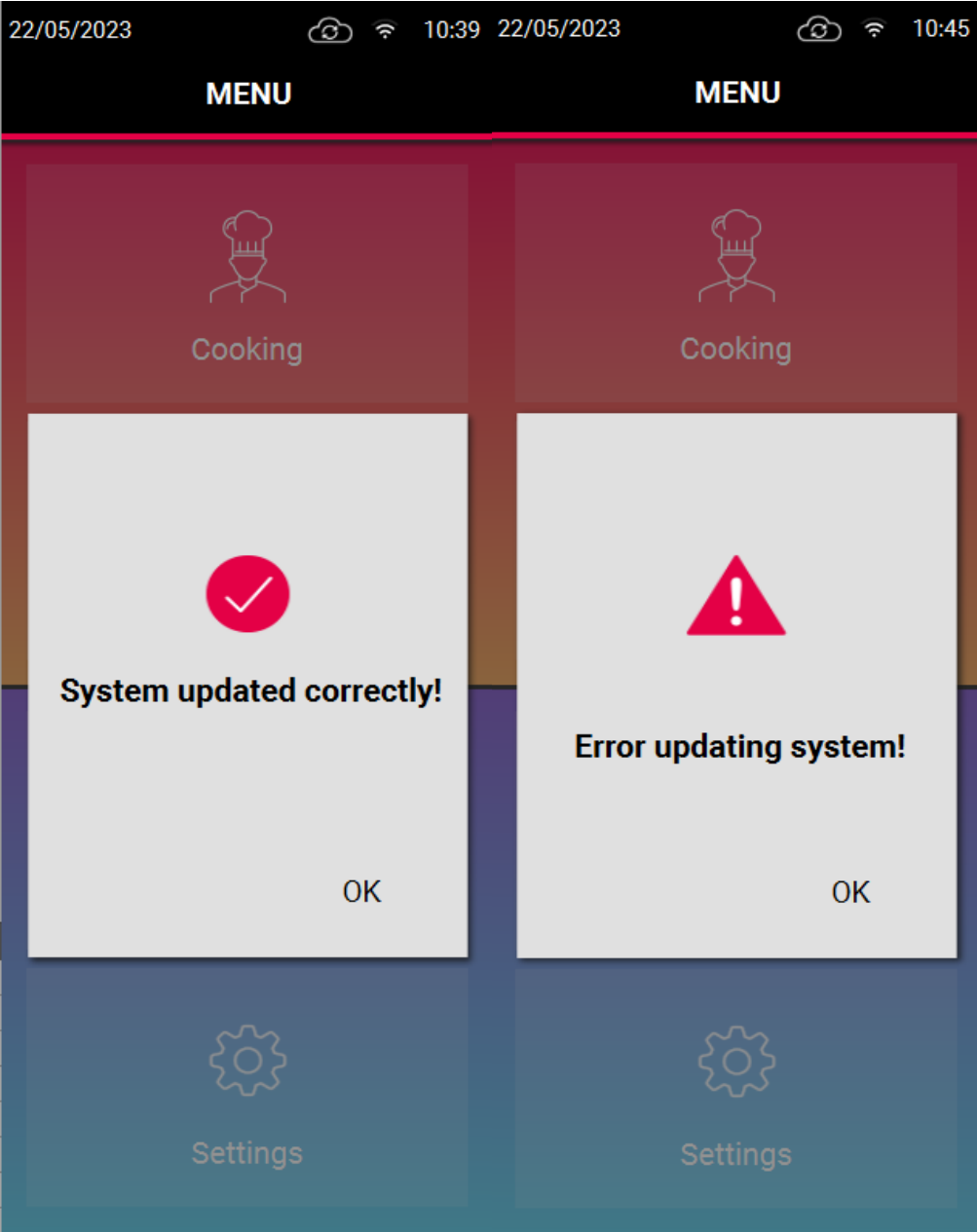

Figure 13. Update verification

6.2.6. Restore factory defaults

To do this, click on the Restore values button. The restore will start automatically.

The option "Generate new Cloud PIN" is used to unlink all the information and statistics of the oven stored in the cloud, so that after the restoration a new Cloud PIN will be generated and it will be necessary to add the oven again in the Cloud.

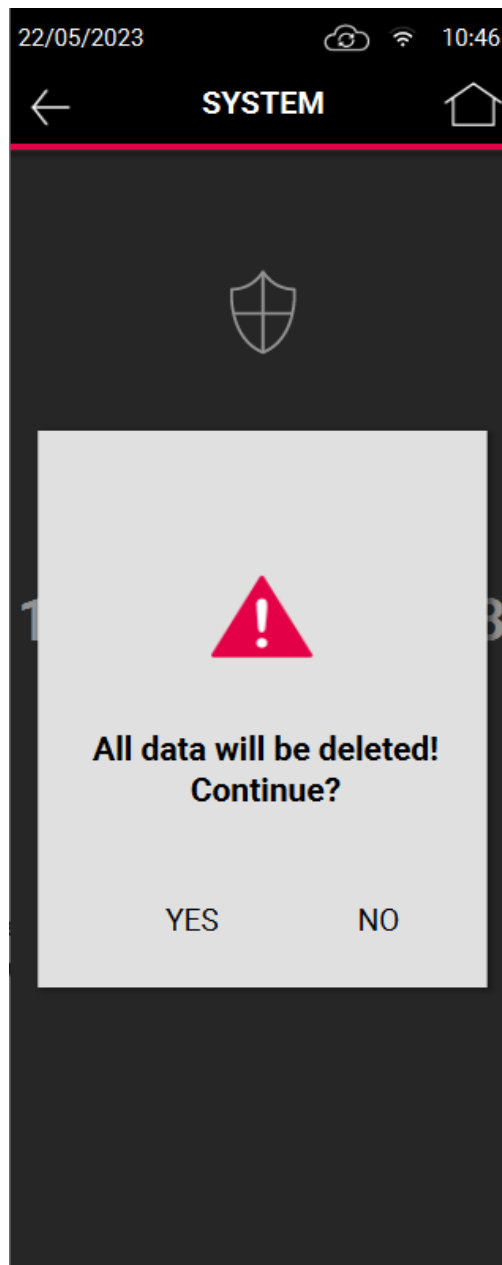

Figure 14. Restore to factory defaults



When restoring to the original settings, all saved recipes and settings are deleted.

6.2.7. Accounts

This option allows us to configure, consult and unlink the corresponding user and oven data, as well as to see the synchronisation status with the Cloud.

The "Synchronisation reminder" option is used to enable or disable the synchronisation reminder at start-up.

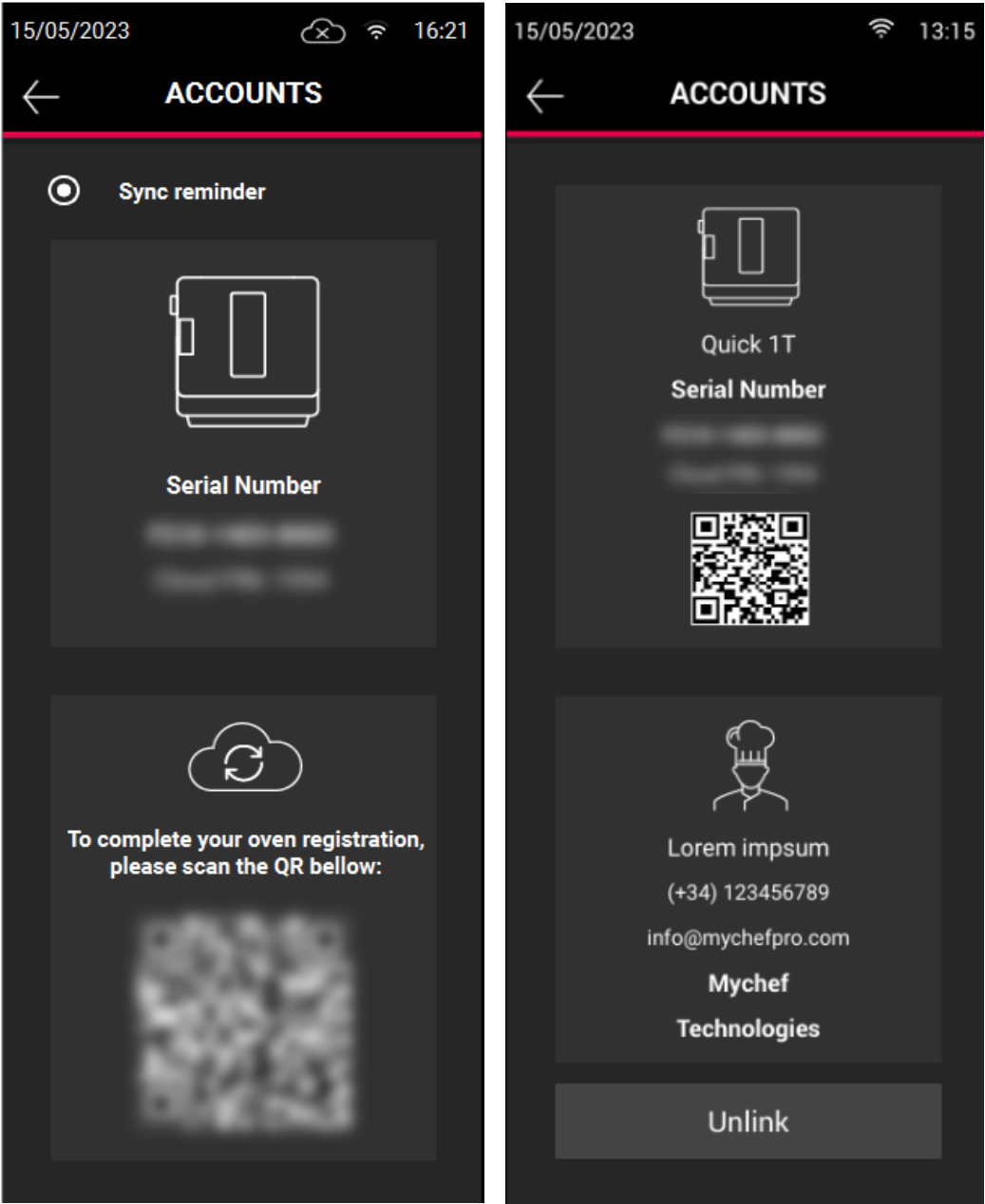

Figure 15. Consultation and configuration of accounts

6.2.8. USB

The equipment allows uploading and downloading of recipes and oven operation information.

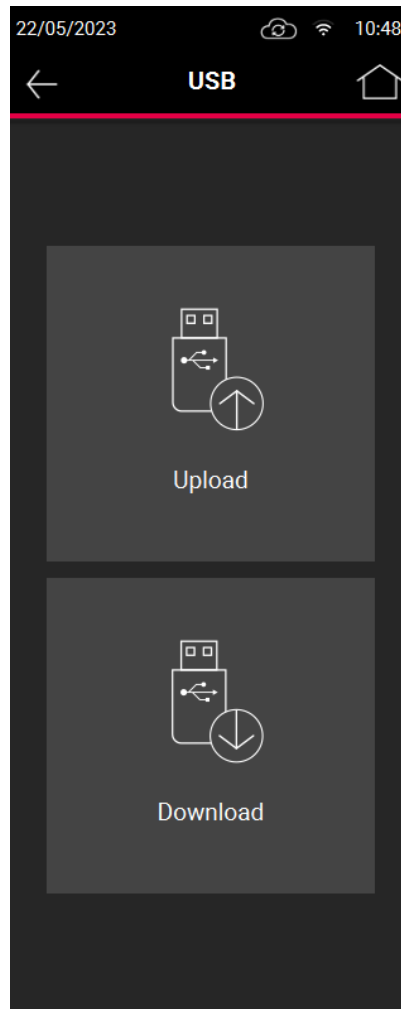

Figure 16. Upload/download USB files

To upload or download data, insert a memory stick into the USB connector on the bottom of the door.

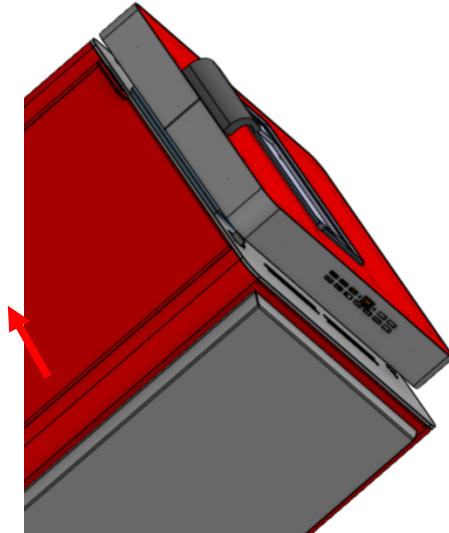

Figure 17. USB memory access



The USB device system must always be FAT32.

6.2.9. Metric system

The oven configuration allows you to work in both the international system of measurements and the Anglo-Saxon system. By selecting one of the two options and pressing the back button, the configuration will be saved, and the system will be restored.

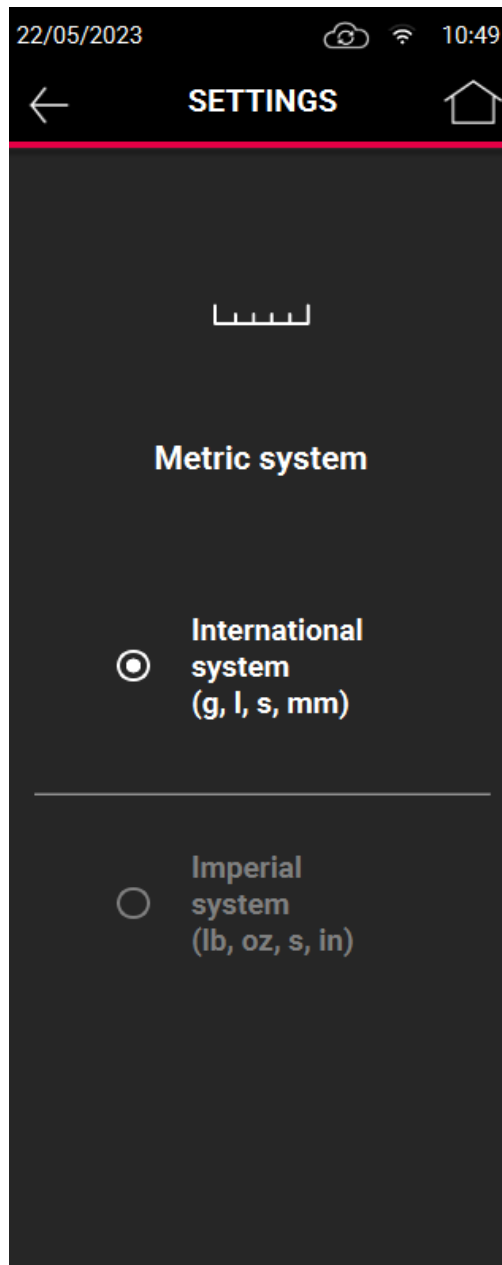

Figure 18. Metric system configuration

6.2.10. Consumption

In this section it is possible to consult the data corresponding to the energy consumption of the oven and the hours of operation of the oven.

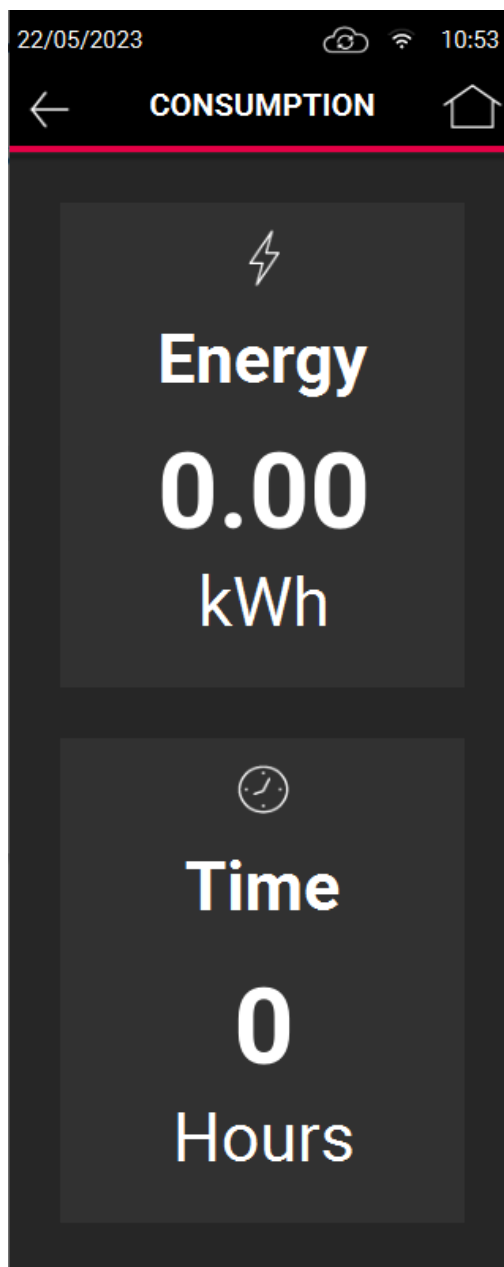

Figure 19. Consumption data

This option allows to consult data related to the user of the oven and the Technical Assistance Service.

6.2.11. Errors and alarms

During the preparation and execution of any of the programmes available in the oven, errors and alarms may occur. If an error occurs in the system during use, it will be displayed in the error list.

The table below shows the different errors and alarms, as well as possible solutions to them.

Error	Internal definition	Clarification
0	NO ERROR	No error.
4	PCB ERROR RELAYS	Communication between boards is not responding. Check the cable connecting the power board and the control board.
6	ENGINE ERROR	Motor error. Check motor wiring. Motor overtemperature. Motor stuck.
23	ERROR PROBE8 TEMP SENSOR NOT CONNECTED	Chamber probe not connected. Check probe and wiring.
24	ERROR PROBE8 TEMP SENSOR SHORTED	Short-circuited chamber probe. Check probe and wiring.
29.XXXX	INVERTER ERROR	Reserved

Table 4. Errors, alarms, and possible solutions

Check whether the errors can be eliminated by your own means, or if not, contact your technical service.

6.3. Mychef Cloud linkage

It is possible to link the device to the Mychef Cloud service. To do this you will need to create a Mychef Cloud account:



To register the oven, you can follow the steps in the section Configuration/Accounts or by using the easy guide:

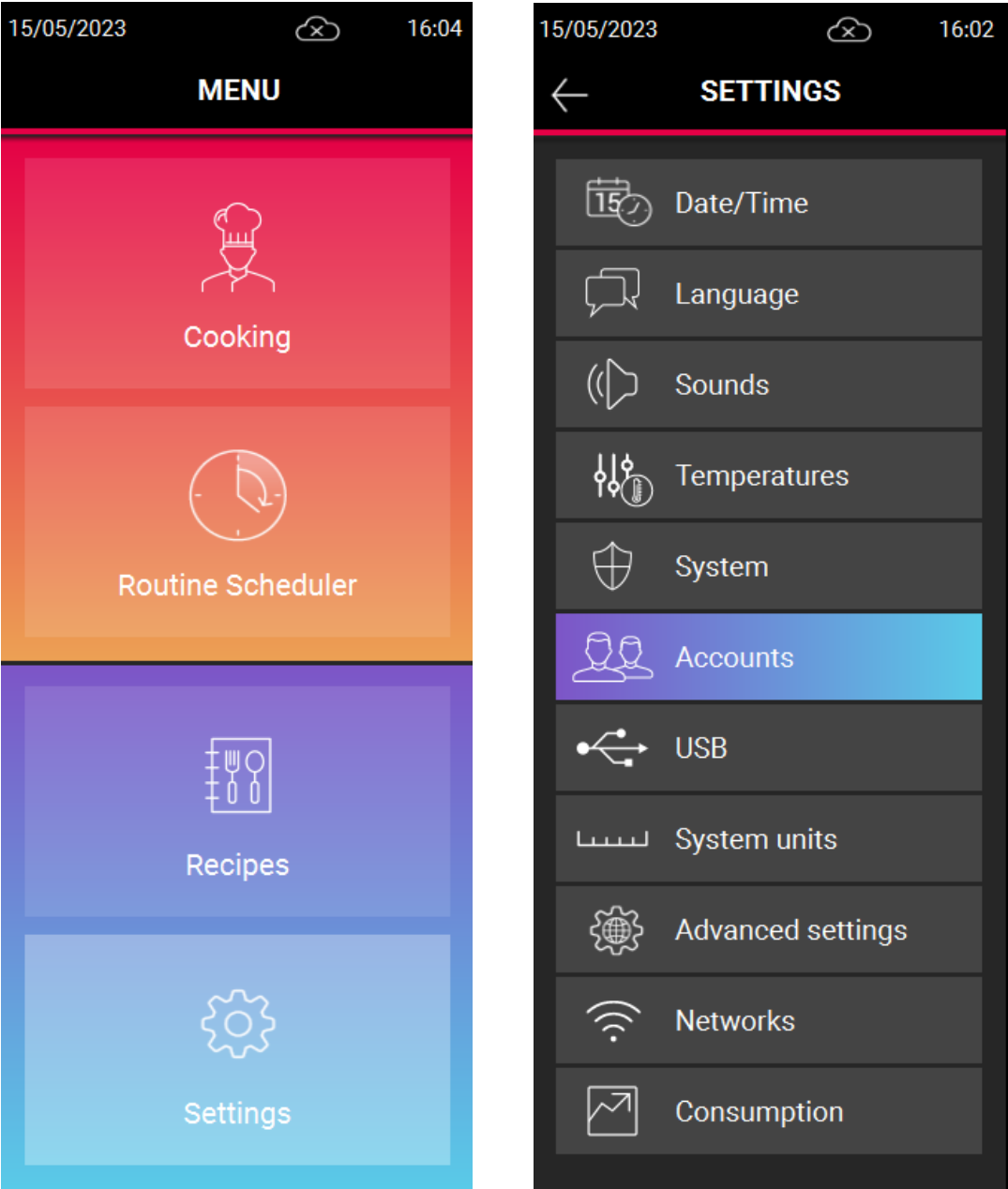

Figure 20. Steps to access the accounts menu

The steps for oven registration are as follows:

6.3.1. Setting up Wi-Fi connection

It is important to set up a Wi-Fi connection for data exchange with Mychef Cloud. To do this, use the "Networks" button on the Accounts screen or in the configuration menu. Once a connection is established with the server, a QR code will be generated with the necessary information to identify the oven.

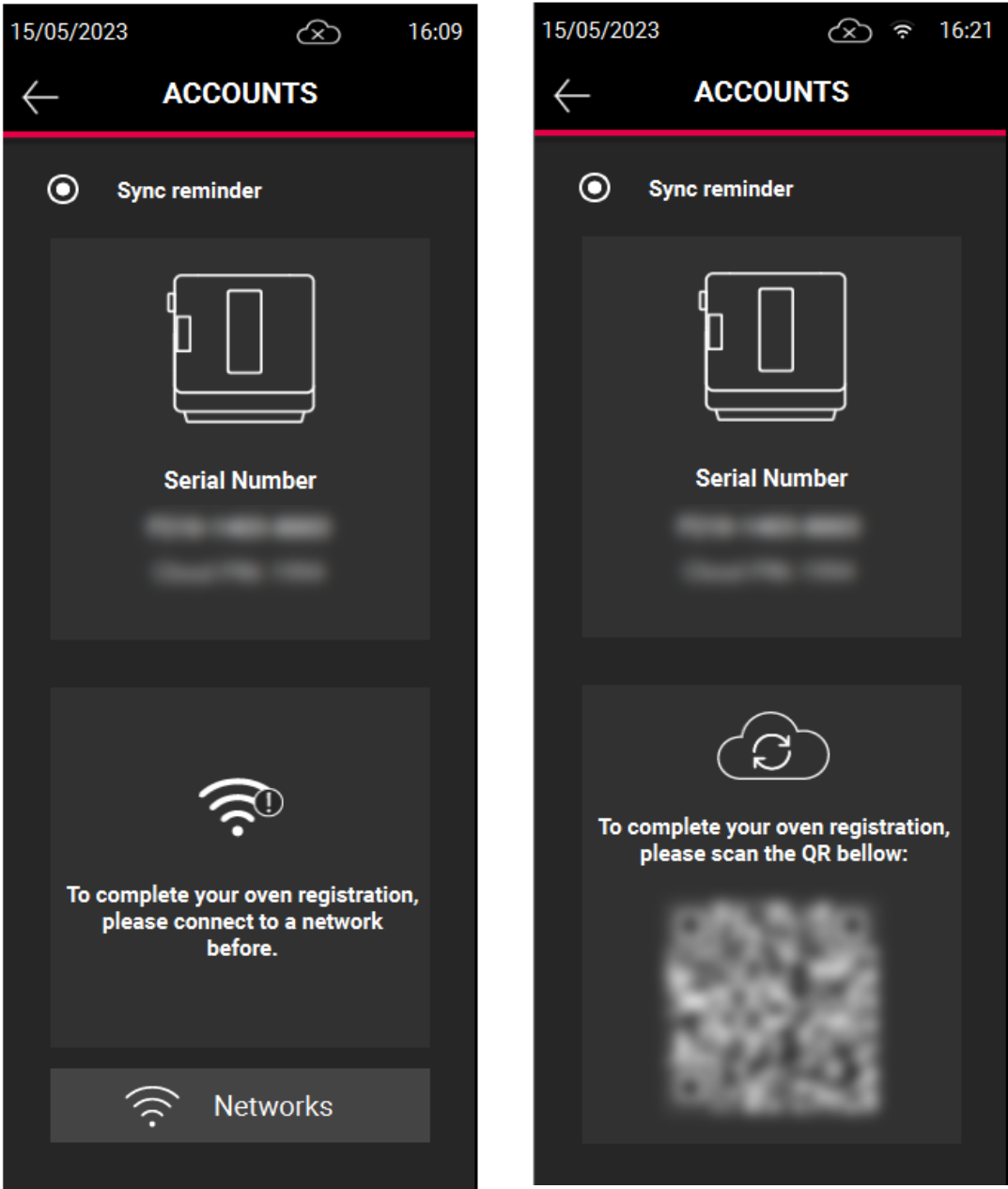

Figure 21. Screen accounts with (right) and without internet connection (left)

6.3.2. Add device in Mychef Cloud

After creating a Mychef Cloud account, it is necessary to enter the information that identifies the oven in order to register the equipment.

Among the information to be entered is the name of the device, freely selectable and which will be used to identify the oven in the different menus of Mychef Cloud, it is also necessary to enter the serial number of the oven and the cloud pin, which can be found in the Accounts screen of the oven (see figure 20 and 21) or in the easy guide.

If Mychef Cloud is accessed via a mobile device, there is the option of adding the device by scanning the QR code that appears on the Accounts screen or on the label of the easy guide, thus autocompleting the fields with the information that identifies the oven.

Finally, the location of the oven will be selected and the registration process will be completed by clicking on the add oven button.

Oven name:

Serial number:

Cloud pin:

To register a new oven:

1. Insert a **Oven name**
2. Go to the **"Settings"** section on your oven's screen.
3. Under "Account," find the "Serial Number" and "Cloud Pin" details.
4. Then, you can scan the QR code shown in the screen or enter in this form the Serial Number and Cloud Pin exactly as they appear on your oven's screen.
5. Make sure that your oven is successfully connected to the network before attempting to register.
6. Insert where the oven is located on the map below
7. Submit the information and complete the registration process.



Insert Location



Figure 22. Add device screen in the web interface

6.3.3. Check correct linkage

Once the above steps have been carried out, the oven must be restarted or stay on the Accounts page to check that it is correctly linked to Mychef Cloud, on this  page the information of the user to which it has been linked should appear. The device is ready to exchange information with Mychef Cloud, from the web application the linked oven should appear as "connected".

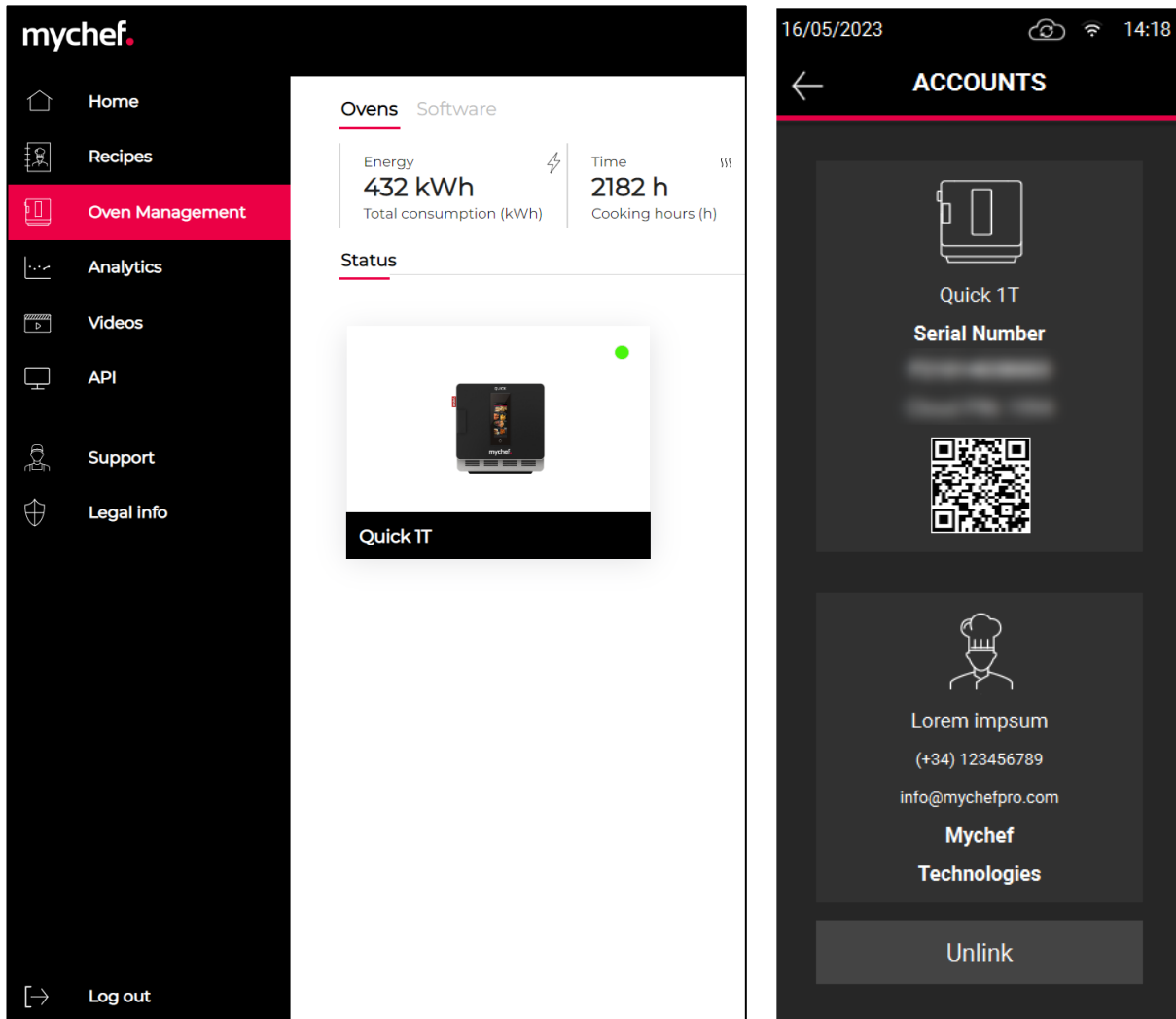

Figure 23. Mychef Cloud page (left) and Accounts screen (right) with the device named "Quick 1T" linked.



In the event that the connection to the Cloud is lost and changes are made to recipes or settings, when the connection is re-established, the information stored in the Cloud will always take priority.

7. USE

This section will give an overview of the basic functions and all the information necessary for the correct use of the user interface of the Mychef QUICK 1T oven.

7.1. Switching on the equipment

The equipment is switched on or off by pressing the circular button (START/STOP) for a few seconds.



In order to protect the oven from possible overheating, some protection elements may operate even when the oven is switched off. When the oven is at a safe temperature, they will automatically switch off.

If the unit does not turn on, check the condition of the safety thermostat, located on the back of the unit. To do this, first remove a black plastic plug located next to the power cable gland.

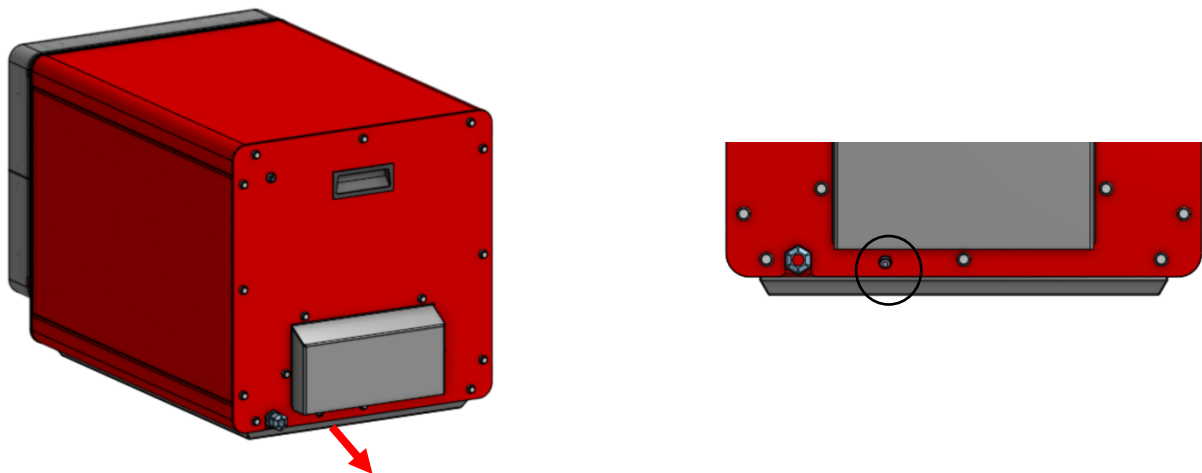

Figure 24. Access to the safety thermostat

7.1.1. First use

Once you have connected your Mychef oven for the first time, the corresponding parameters must be set (Section 6.2). The oven is then ready for operation.

7.2. Main menu

Once the oven has been configured, every time the oven is switched on, it will automatically enter the main menu (manager mode) or the temperature menu (user mode) unless a switch-on temperature has been set in the routine programmer (see section 7.2.2).

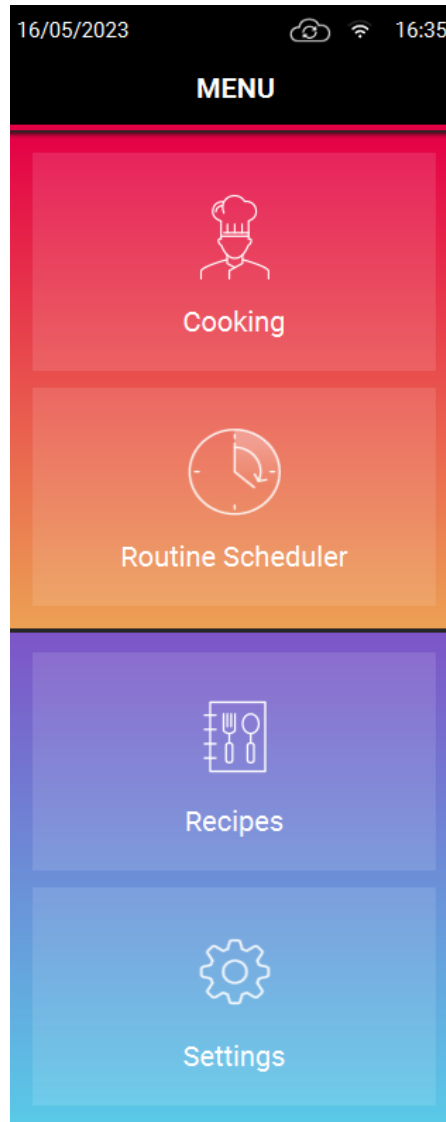

Figure 25. Main menu display

The header present on all screens displays different information and buttons to interact with:

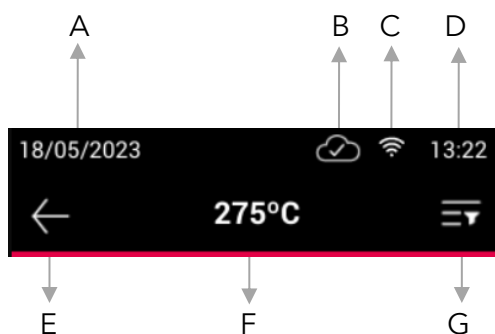

Figure 26. Header functions

A	Current system date	
B	Synchronisation icon with Mychef Cloud	
		Correct synchronisation.
		Synchronising.
		Synchronisation error.
C	Wi-Fi signal	
D	Current system time	
E	Back. Return to the previous screen	
F	Current screen information	
G	Header interaction button	
		Switches to Manager mode
		Switches to User mode
		Return to the main menu
		Allows you to filter the display of recipes
		Allows you to delete the selected recipe

Table 5. Header functions and icons

The oven has two types of access:

	Manager	It allows you to navigate through all the oven options, edit the settings, create or delete recipes and program the Routine Scheduler.
	User	It allows you to select the operating temperature and to make recipes, both those you have created and those with time.

Table 6. User access modes

To activate the "User" access mode, press the check in the upper right corner of the temperature selection menu. To return to the "Manager" access mode, press the back arrow in the temperature menu or press the padlock button and enter the password 357.

7.2.1. Cooking

In this screen we can select the temperature at which we want the oven to work. Once the temperature has been selected, the oven will adjust the temperature until the chamber reaches the selected temperature. To skip the Preheat press the circular button (START/STOP).

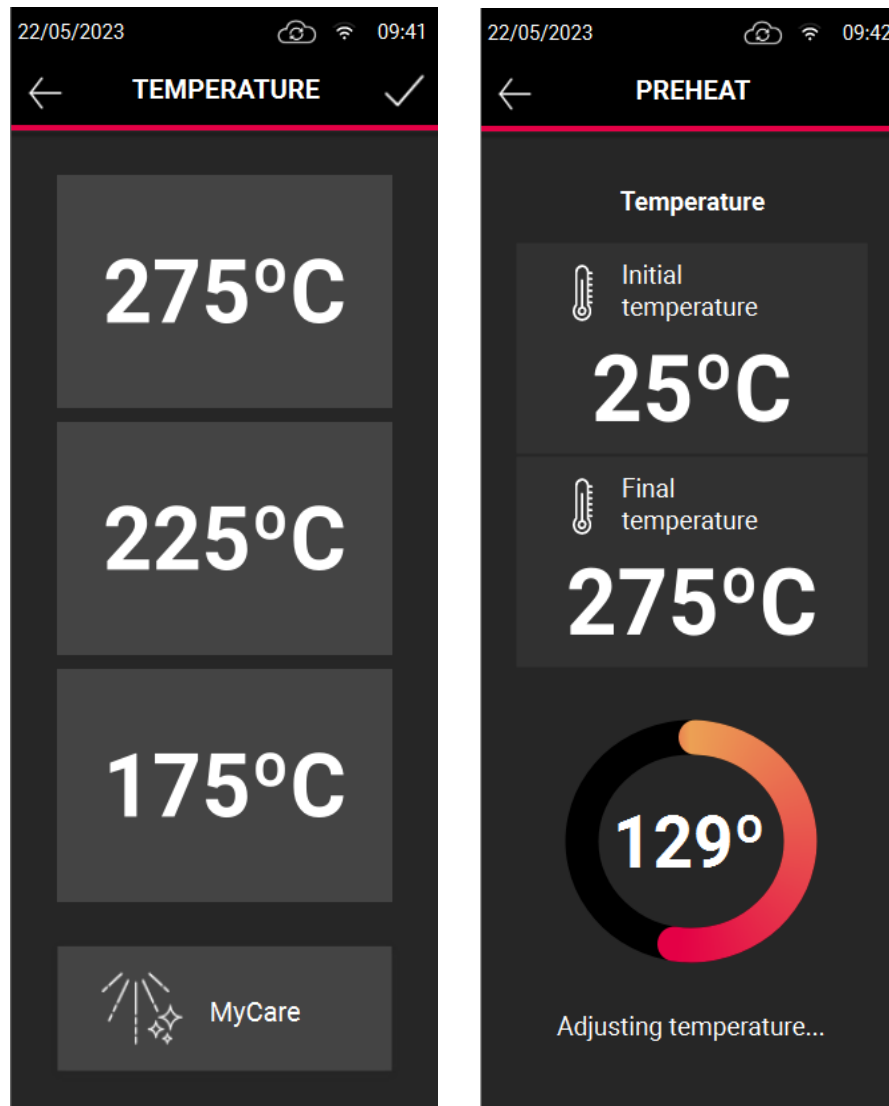

Figure 27. Temperature selection and preheating

When the oven reaches the indicated working temperature, the recipe menu will appear, where the recipes compatible with the selected working temperature will be displayed. If it

is necessary to change the working temperature, select the arrow in the top left-hand corner to return to the temperature selection menu.

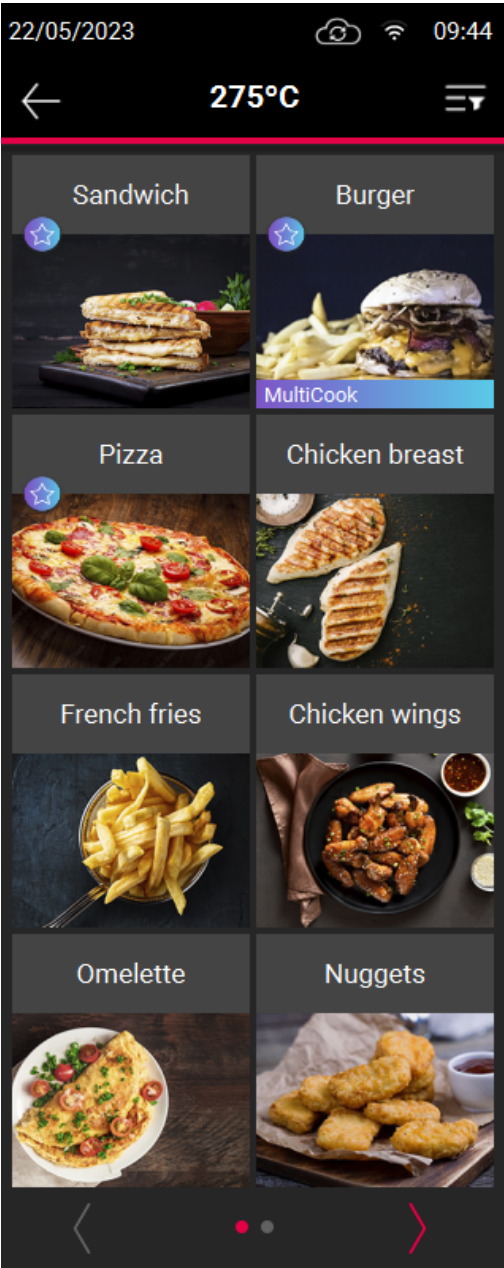

Figure 28. Recipes' menu

In the recipes menu we can open a drop-down menu, in the top right-hand corner, where we can filter the recipes that the oven has:

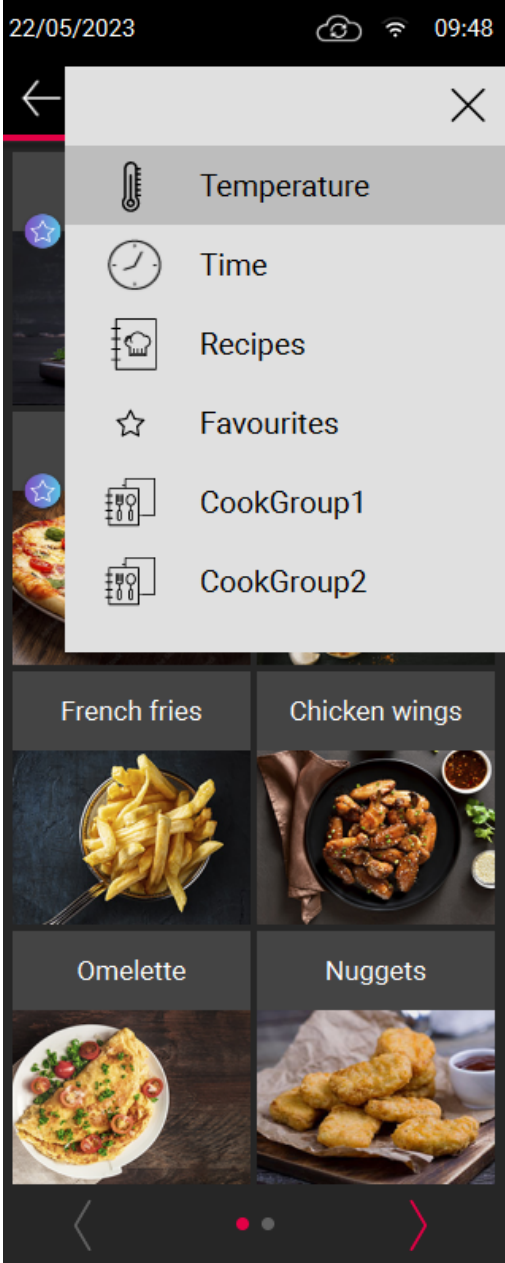

Figure 29. Recipe filter





	Recipes compatible with the selected temperature
	Time recipes
	All recipes
	Favourite recipes
	Groups of recipes

Table 7. Recipe filter options

If no recipe has been saved for the selected temperature, the time recipes will appear in the recipe menu after the temperature setting process has been completed.

7.2.2. Routine Scheduler

The Routine Scheduler allows the user to program the switch-on time and the temperature to be reached, as well as to program the switch-off time.

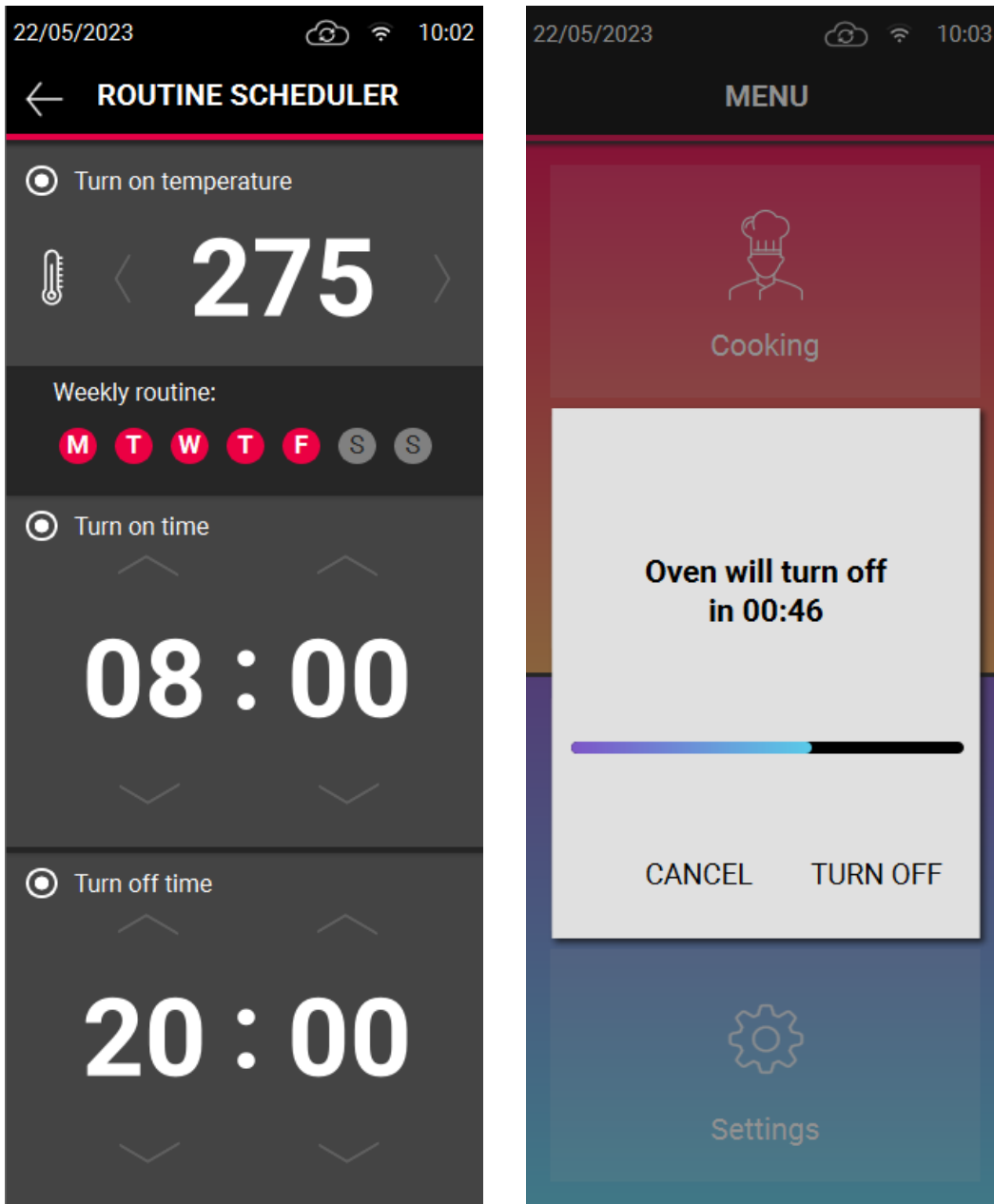

Figure 30. Routine Scheduler

The first parameter to set is the day or days of the week on which you want to perform the switch-on or switch-off routine.

If "On time" is activated, the oven will always switch on at the selected time, and will start in the temperature selection menu or in the main menu, depending on whether the user mode configured is "Manager" or "User" (See **Table 6. User access modes**).

If the "On temperature" is also activated, when the oven is switched on, it will automatically preheat until it reaches the working temperature and keep it stable.

If the "Switch-off time" is activated, a progress bar will appear two minutes beforehand with a message to cancel the switch-off, or the option to switch it off immediately, after two minutes, if no button has been pressed, the oven will switch off.

7.2.3. Save Recipes

The Mychef QUICK oven allows the user to store up to 1024 recipes.

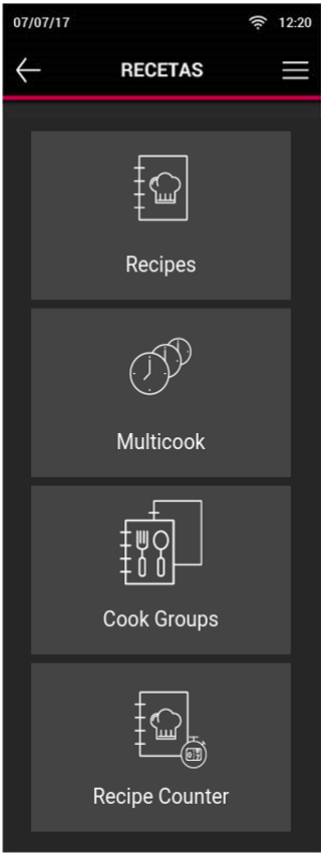

Figure 31. Recipe configuration menu

To create a recipe, the temperature, time and fan speed parameters must be configured. We can also name the recipe and add an image¹ which can be loaded from a USB memory stick by scrolling through the recipe image selection arrows.

Once all parameters have been set, select the "SAVE" button.

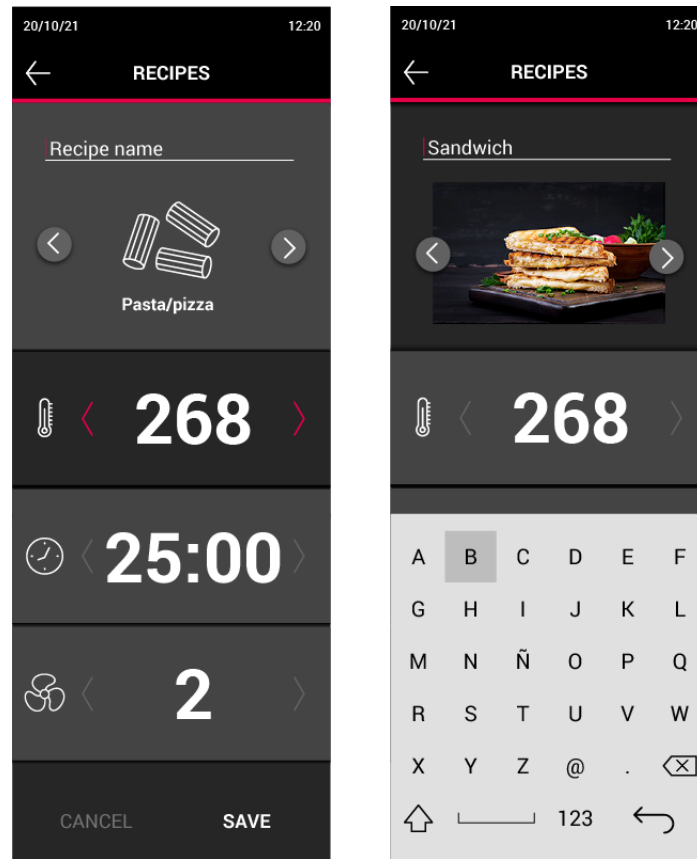

Figure 32. Save recipe

¹ The dimensions for an optimal display of the images are 267x172px and the supported image formats are JPG and PNG.

The MultiCook cooking mode allows you to cook different foods in baskets that require different cooking times for a complete recipe.

To load a cooking operation into MultiCook mode, press the button on the display and set the temperature, time and fan speed parameters for each food. Once all the parameters have been selected and set, press the save button. The fan speed and temperature will always be the same within a MultiCook recipe and will be the same as those selected for the first food.

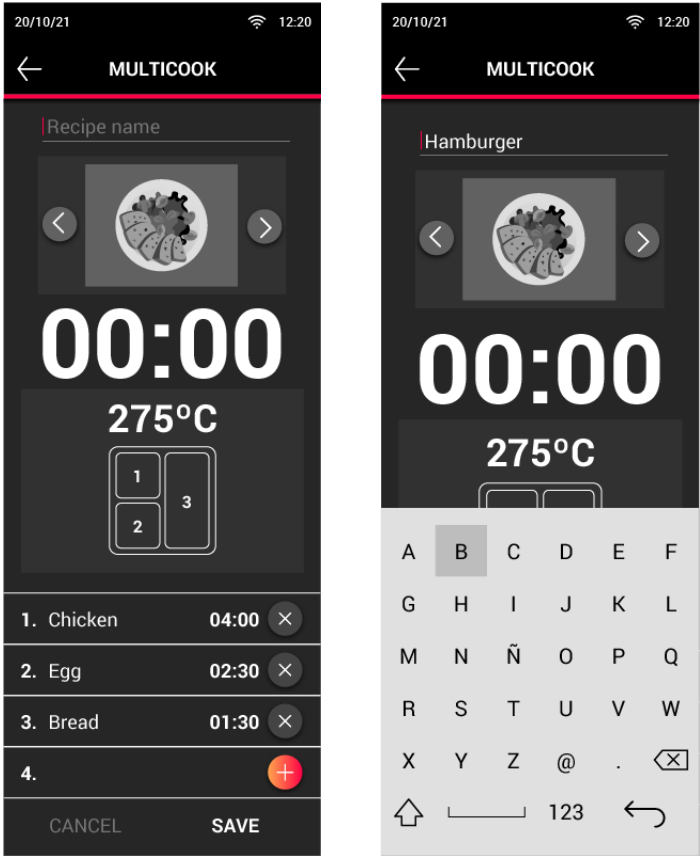

Figure 33. Save MultiCook Recipe

The recipes are rearranged according to time, the longest time will be tray 1. The shorter times will be placed in the outer baskets.

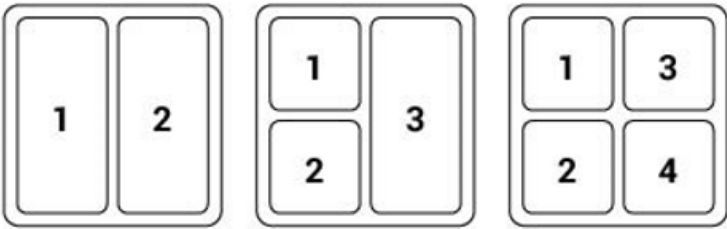

Figure 34. Basket organizer

To modify a recipe already created, click on the recipe you wish to edit to return to the edit menu. If you press the recipe continuously for a few seconds, an icon will appear to delete it.

There is also the possibility to create groups of recipes, so that the user can sort them by breakfast, lunch, or dinner recipes. Each group of recipes can be identified by a name of the user's choice and group up to 10 recipes.

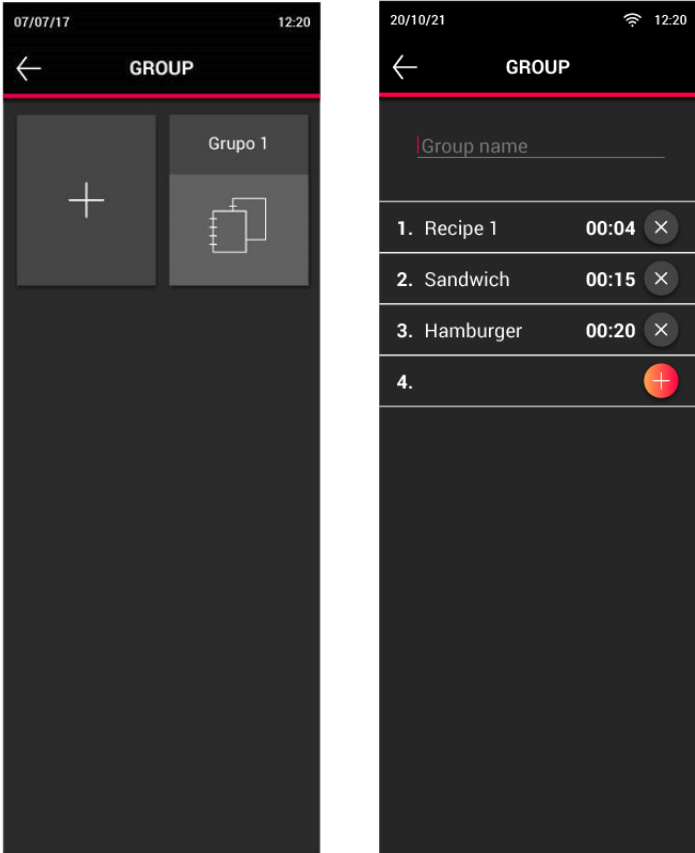

Figure 35. Groups of recipes

These recipe groups can be displayed in the recipe menu by filtering by cooking groups (Section 7.2.1) or in the recipe configuration menu by selecting "Cooking groups".

In the Counter section of the recipe configuration menu, we can find a list with the number of times each recipe has been executed. To reset the values to zero, select the Reset option at the bottom of the screen.

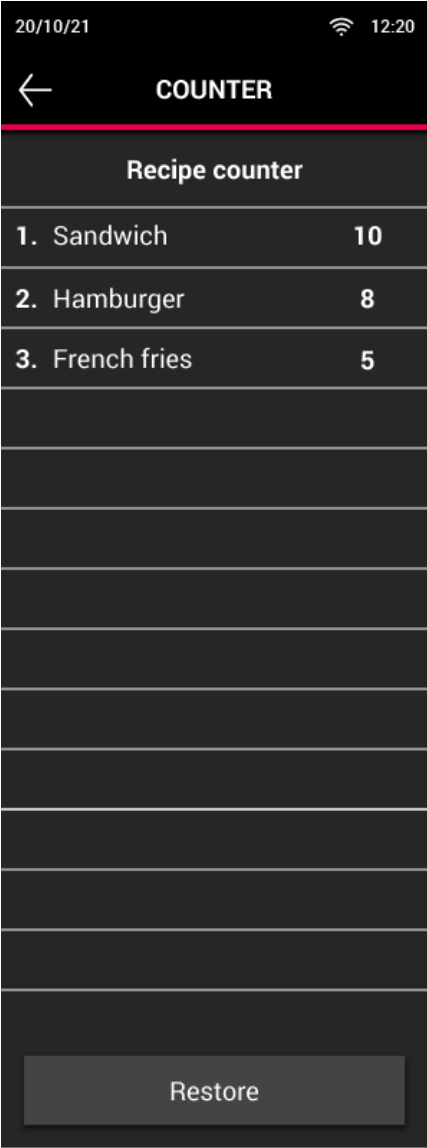

Figure 36. Recipe's counter

7.3. Cooking

7.3.1. Cooking a recipe

To start cooking a recipe, first place the food inside the chamber. Once the door is closed, select the recipe and the cooking procedure will start. A progress bar will appear indicating the remaining time, the photo of the food and the temperature and total time of the recipe.

To cancel the cooking procedure, press the circle button (START/STOP).

Cooking ends when the cooking time has finished. At the end of a cooking cycle, the appliance indicates this status visually and acoustically. In particular:

- An acoustic signal is emitted.
- The cooking finished message appears on the display.

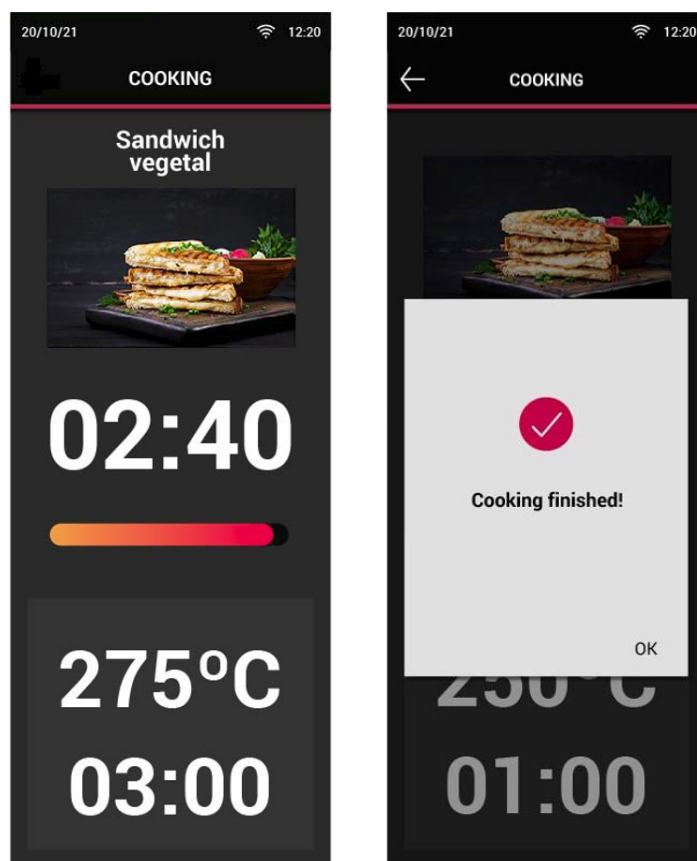

Figure 37. Cooking process

7.3.2. Cooking MultiCook recipes

For cooking that starts at the same time, under a single cooking cycle and different end times depending on the recipe of each basket. The system will notify the user via the display when to remove each basket at the end of cooking. Cooking will stop when the door is opened. When closing the door the process will resume.

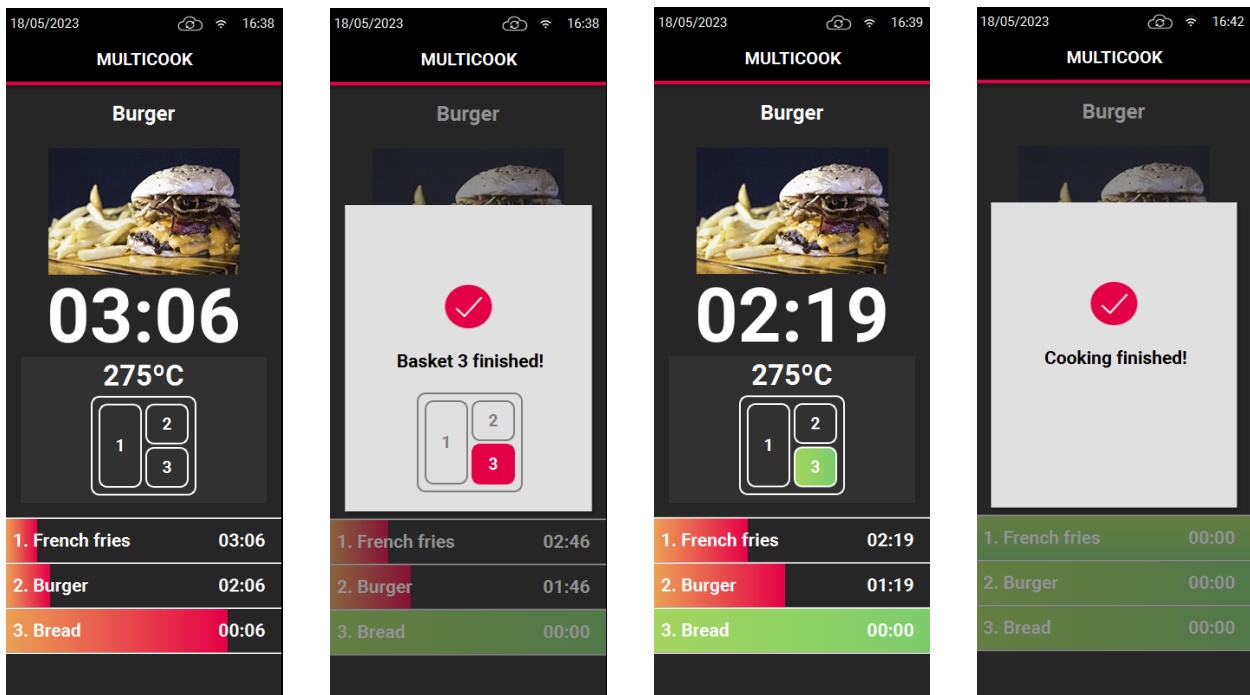

Figure 38. MultiCook cooking process

7.3.3. Recipe information

In the recipe menu, by clicking continuously on the image of each recipe, the cooking parameters will appear. On this screen it is also possible to save the recipe as a favourite.

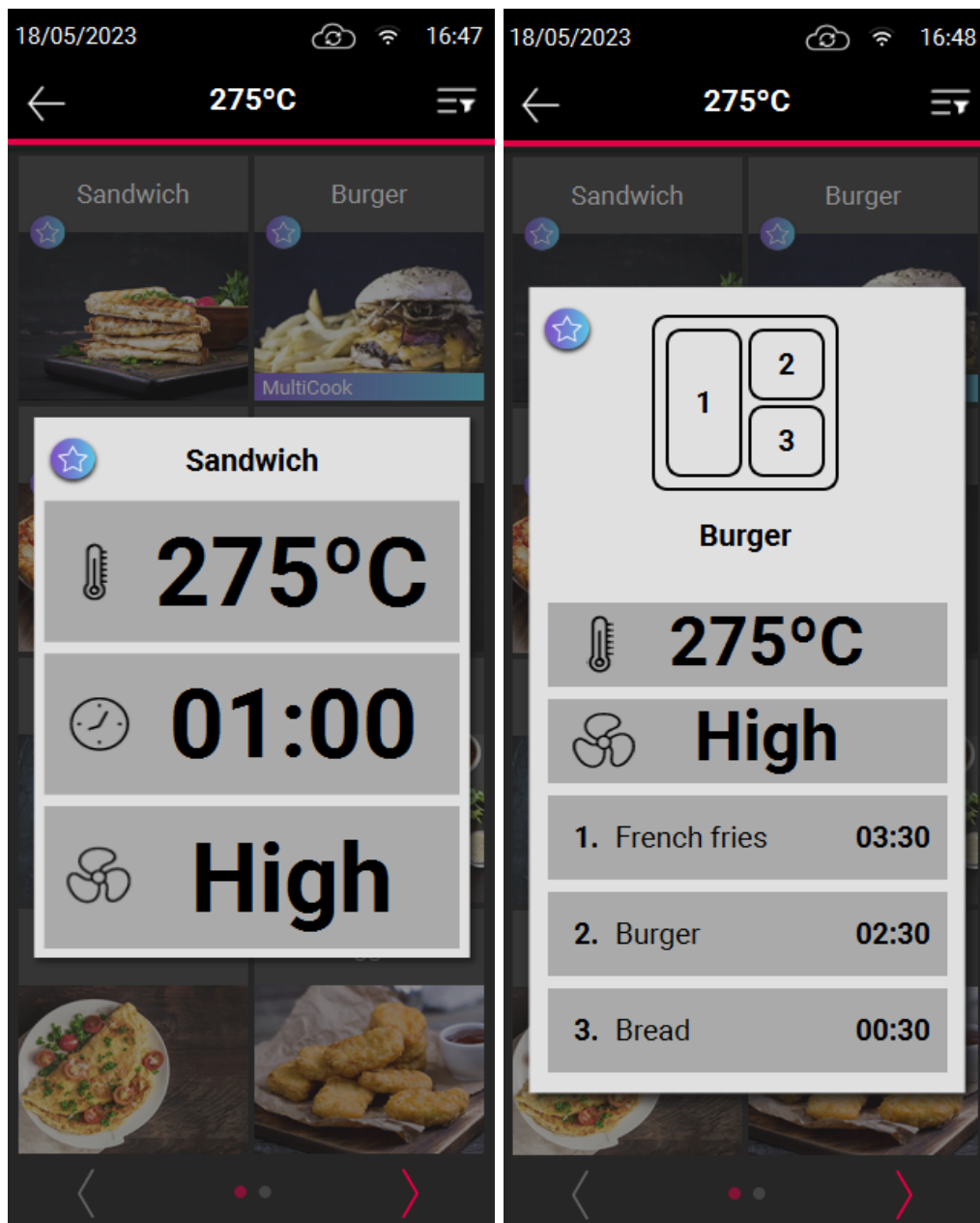

Figure 39. Recipe information

7.4. MyCare

Before cleaning the oven (Section 8.1), it must be cooled. To do this, go to the temperature menu and select the MyCare option. Selecting MyCare activates the oven fan at maximum speed to cool the chamber. It is recommended to put a container of ice inside the chamber and perform the MyCare with the door open to speed up the cooling process. It is also possible to cool the cooking chamber by leaving the door open.

The MyCare will end when the oven chamber reaches a temperature of 50°. The chamber can then be cleaned or disassembled for further cleaning.

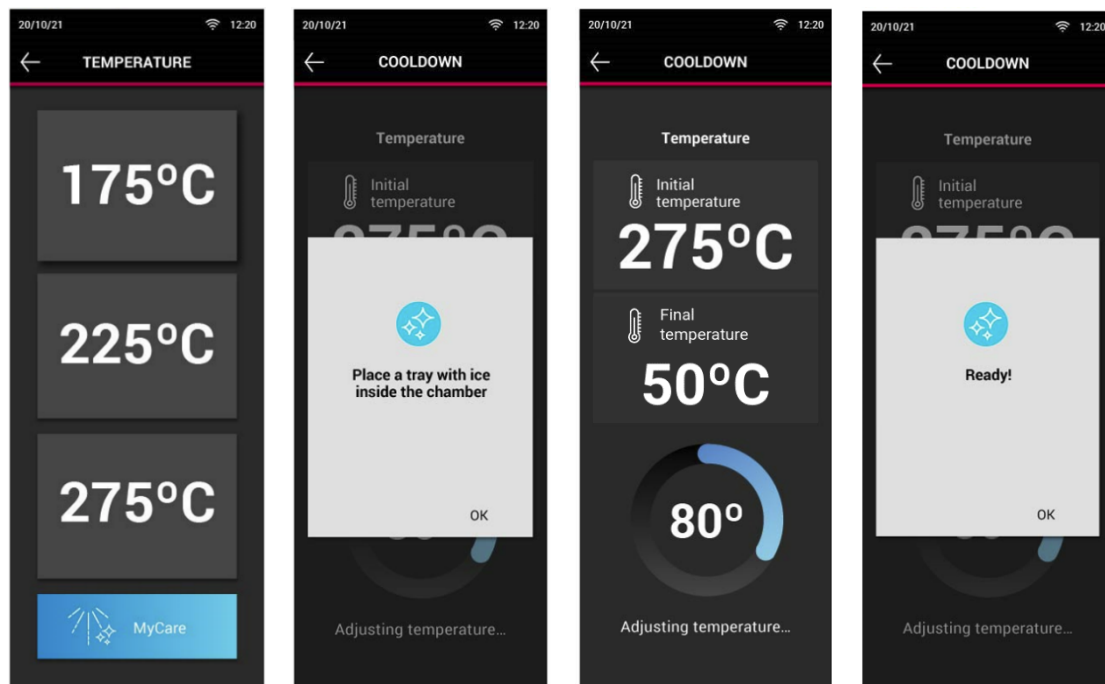

Figure 40. MyCare

8. MAINTENANCE



Any ordinary maintenance operation must be carried out after disconnecting the equipment from the mains.



Suitable protective equipment must be worn for all maintenance operations.

8.1. Cleaning

It is the responsibility of the owner to carry out regular maintenance and cleaning. In order to maintain the warranty, it must be possible to prove that the maintenance has been carried out correctly and according to the instructions detailed in this manual.

One of the important parts of the maintenance of the equipment is the cleaning of the equipment. Therefore, the equipment should be cleaned more or less frequently depending on the area of the equipment.

The table below shows the frequency with which the different parts of the equipment must be cleaned.



Under no circumstances may the equipment be cleaned with any pressure or steam apparatus.

Part of the device	Frequency
Inside the chamber	Daily
Compartment behind the suction plate	Daily
Door gasket	Daily
Equipment envelope	Daily
Removable inner plates	Daily

Table 8. Cleaning frequencies for Mychef QUICK 1T oven

Before starting any cleaning programme, trays, racks, grids, or other accessories inside the chamber must be removed.

8.1.1. Suction and door gasket

8.1.1.1. Aspiration

In order to clean the inside of the chamber, a cooldown must be performed in the oven to lower the internal temperature. The cooldown can be performed with the door closed or with the door open to facilitate the cooling of the chamber.

Once the chamber has reached a temperature of 50°C, the cooldown is ended, and cleaning can begin.

First remove the tray (A) by sliding it out, without any further operation.

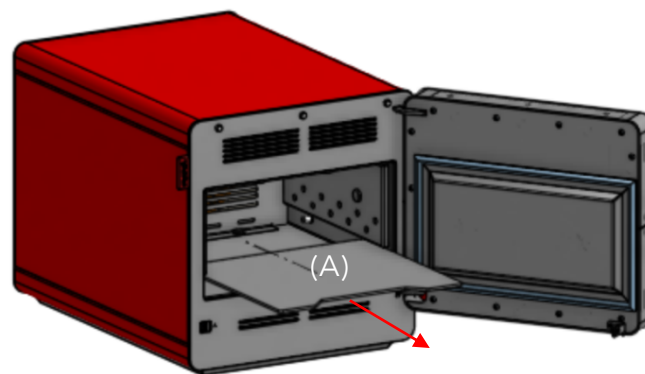

Figure 41. Tray extraction

Next, the side plates (C) are removed from inside the chamber. First unscrew the screws (B) on both the right and left sides. Once removed, the plates are removed by sliding them outwards.

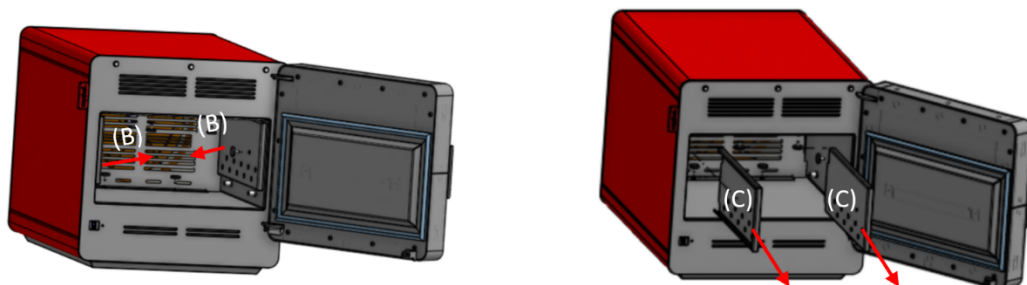

Figure 42. Removal of screws and lateral plates

Once the side plates have been removed, you have access to the plate separating the cooking chamber from the fans and the heating element (D). To remove it, unscrew the screws (B), two at the top and two at the bottom. Preferably unscrew the screws at the bottom first. Once they have been unscrewed, the plate can be removed as indicated in Section 5.2.

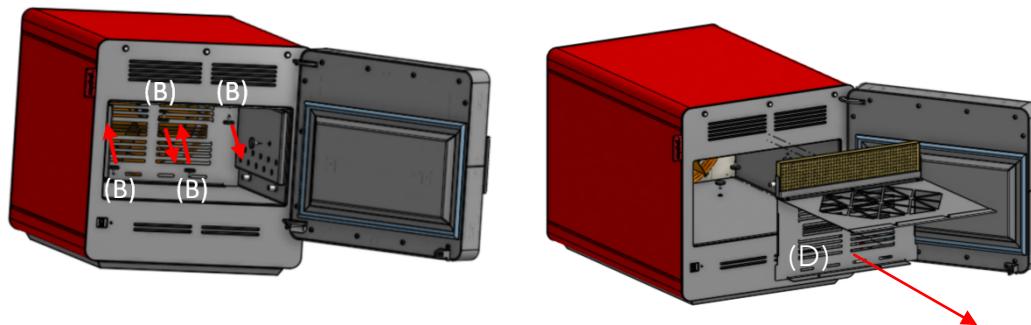

Figure 43. Removal of the cover plate

8.1.1.2. Door gasket

It is important that this part of the oven is clean and free of any encrusted food pieces so that it can seal the chamber well and heat, water or steam cannot escape when it is in operation.

To clean this rubber gasket, we can remove the plate (E) on which it is located for easier cleaning of the weatherstrip.

The door gasket should not be removed from its contour for cleaning but should only be removed when it needs to be replaced.

To remove the plate containing the weatherstrip, pull it upwards and then outwards so that it comes out of the guide.

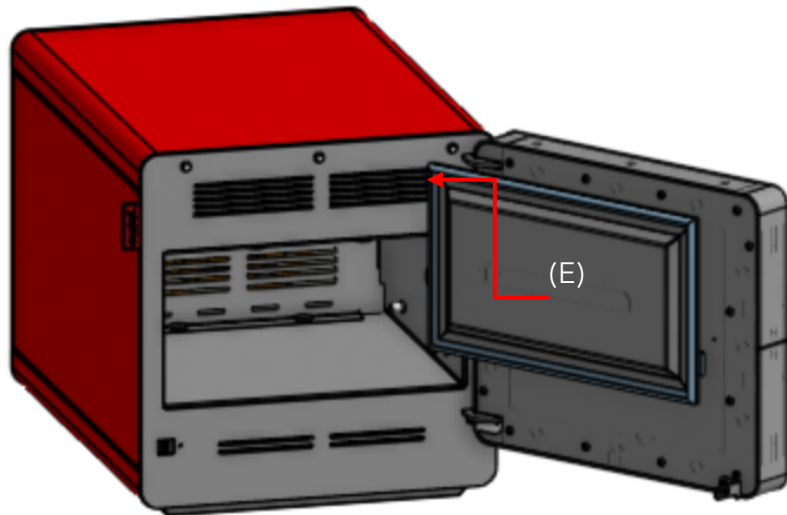

Figure 44. Removal of door gasket plate

Once all the plates have been removed from inside the chamber and the door gasket plate, they can be cleaned. The plates can be cleaned either manually or by placing them in a dishwasher. The cleaning will always be carried out with Mychef liquid detergent for high speed ovens.



Use extreme caution when cleaning this part of the oven. Leave the door ajar and wait until the chamber fan stops.



The catalytic filter and its compartment are an accessory.



The catalytic filter must not be put in the dishwasher under any circumstances, nor must any solvents, detergents, etc. be used.

When all the parts have been cleaned, they must be dried completely and Mychef high speed oven protection liquid must be applied.

Then place the pieces in the reverse order in which they were removed.

8.1.2. Outer casing

To clean the outer casing, use a cloth with the protective conservation product, so as not to damage the outer finish. Then rinse and dry.

8.1.3. Control panel

To clean the control panel, use a cloth dampened with dishwashing soap and water. Then rinse and dry.

Never use agents containing alcohols or solvents, as they may attack the metals or plastics of the control panel.

8.1.4. Accessories

Clean the oven accessories regularly and carefully. Always clean with a cloth dampened in water and neutral soap.



The cleaning of the accessories must be done with a cloth dampened with water and no chemical products must be used on them. DO NOT USE ANY LIQUIDS CONTAINING ALCOHOL, ACID, DETERGENTS, SOLVENTS OR EQUIVALENT FOR CLEANING.

8.2. Preventive maintenance

Mychef ovens are designed for intensive and long-lasting operation. To ensure this, in addition to regular cleaning, preventive maintenance must be carried out. This preventive maintenance is specifically designed to prolong the life of your Mychef oven, minimize energy and water usage, and ensure uninterrupted excellent cooking quality.

This maintenance programme is segmented into different types of overhauls, which should be carried out approximately every year or 2,000 working hours, whichever comes first.



These periodic inspections must be carried out every 2,000 working hours or every year, whichever comes first.



These periodic inspections must be carried out by an authorized service technician.

The following table shows the operations to be carried out on Mychef ovens in each of the revisions. The table is circular, and after 20,000h of use or 10 years of use, the time would start to count again from the left of the table. That is to say, at 22,000h the 2,000h revision A would correspond.

Mychef maintenance programme		2000	4000	6000	8000	10000	12000	14000	16000	18000	20000
Revision A	Firmware update	X	X	X	X	X	X	X	X	X	X
	Cleaning cooling fans	X	X	X	X	X	X	X	X	X	X
	Electronic cleaning	X	X	X	X	X	X	X	X	X	X
	Weatherstripping replacement and door adjustment	X	X	X	X	X	X	X	X	X	X
Revision B	Temperature calibration		X		X		X		X		X
	Adjustment of the inner bolts and nuts		X		X		X		X		X
Revision C	Engine change					X					X
	Replacement of resistor and gasket					X					X
	Replacement of internal seals					X					X

Table 9. Periodic maintenance table



Regular maintenance ensures that your oven will always work as designed.



Periodic maintenance must be proven for warranty validity.



Before any manipulation for maintenance or repair, the equipment must be disconnected from the mains supply.



If the power cord is damaged, it must be replaced by your after-sales service or similarly qualified personnel in order to avoid hazards.