



**Catalogue**  
FOOD SERVICE  
**Chapter**  
COOKING

**Specific model**  
B-G910 | LPG

19078582

11/11/2021

**DENOMINATION:**

Countertop LPG gas grill, stainless steel grill, 1 module, 900 range.

**DESCRIPTION :**

- Surface tops manufactured in 2 mm thick AISI-304 stainless steel.
- Laser-cut joints, automatic welding and polishes. Screws hidden from view.
- Grills fitted with 130 mm high dismountable guard to avoid splashing, manufactured in stainless steel.
- High temperature enamelled cast iron flue protector.
- Access to the components from the front.
- Machines with IPX5 grade water protection.
- In the models with stainless steel grill, this is manufactured with sheets of AISI-304 in "V" shape to facilitate cleaning.
- The grills reach a very high temperature (400 °C), meaning that the surface of the product seals rapidly, keeping the inside of the food much juicier.
- Groups of high-efficiency tube burners, (a group of two burners for half-sized module models, two groups for a single module models).
- Independent control for each group of burners via a safety valve with a thermocouple.
- Burners turned on using Piezo electric ignition.
- The burners heat ceramic stones that sit on a supporting rack, so that they can then heat food on the grill.

**POSSIBLE ACCESSORIES :**

- STANDS 900
- ACCESSORIES KORE
- ACCESSORIES FOR CHARCOALS KORE
- TALL CHIMNEY KORE

**SUPPLIED ACCESSORIES:**

- 19058313 Scraper for charcoal with stainless steel grill Kore generation 1

**DIMENSIONS**



X Width	800 mm	X Gross width	822 mm
Y Depth	930 mm	Y Gross depth	1040 mm
Z Height	290 mm	Z Gross height	535 mm
Net Weight	70,0 kg	Gross Weight	88,0 kg
Net volume	0,170 m3	Gross volume	0,457 m3

**ELECTRICITY TECHNICAL SPECIFICATIONS**

Voltage N/A

**GAS TECHNICAL SPECIFICATIONS**

Gas type LPG

Gas power 22,00 kW

Gas consumption 1,710 kg/h

Regulated LPG G30/G31 28-30/37 mbar  
NG G20/G25/G25.1 20/25/25 mbar



Catalogue  
**FOOD SERVICE**

Capítulo  
**COOKING**

Modelo  
**B-G910 | LPG**

19078582

11/11/2021

### **B-G905**

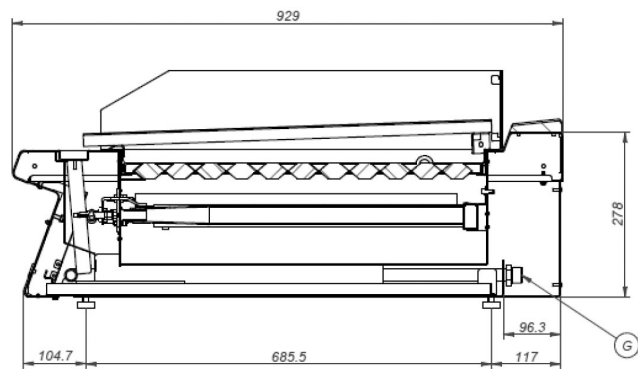
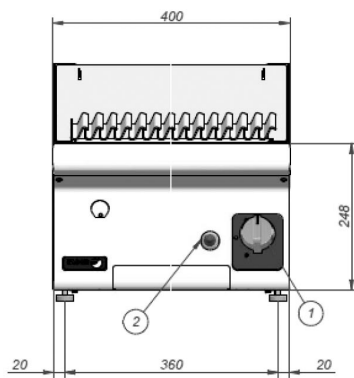

### **B-G910**

