



Catalogue
FOOD SERVICE
Chapter
COOKING

Specific model
MCIE-500 M 50-60 Hz 380-400V 3N

19084231

16/11/2021

DENOMINATION:

Cylindrical boiling pan with mixer indirectly heated electric 500 L

DESCRIPTION :

- Well with AISI-316 stainless steel bottom with a thickness of between 20/10 and 40/10, suitable for products that are particularly acidic.
- AISI-304 stainless steel cooking well walls with thickness of between 20/10 and 25/10.
- Tank drainage hole with a removable filter.
- 2" front drainage tap with insulated athermic handle.
- Double wall with AISI-304 stainless steel bottom and walls.
- AISI-304 stainless steel cover with a thickness of 15/10, fitted with a chromed steel zip with preloading springs and an athermic handle.
- Gauge for controlling pressure inside the double wall.
- Manual air escape valve for depressurising the air produced in the double wall during the heating process.
- Stainless steel supporting structure with a thickness of 30/10 fitted on steel feet with an adjustable height.
- AISI-304 satin stainless steel external walls with a thickness of 10/10.
- AISI-304 stainless steel satin shelf with a thickness of 15/10.
- Removable inner coating to enable easy inspection of internal parts.
- Heat insulation guaranteed by high-density ceramic fibre plates.
- Mixing system:
 - . AISI-316 stainless steel mixer with an adjustable rotation speed of between 7 and 28 g/m with a force of up to 386 N·m
 - . Possibility to reverse the operating direction with the electronic switch.
 - . Removable mixer to ease cleaning and product extraction.
 - . Mixer fitted with stainless steel radial arms and Teflon ceramic blades."
- "- Normal version: safety valve with a spring set to 0.5 bar."

POSSIBLE ACCESSORIES :

- ACCESSORIES LARGE CAP.

DIMENSIONS

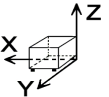

X Width	1420 mm	X Gross width	1490 mm
Y Depth	1300 mm	Y Gross depth	1490 mm
Z Height	1050 mm	Z Gross height	1410 mm
Net Weight	235,0 kg	Gross Weight	315,0 kg
Net volume	1,938 m3	Gross volume	3,130 m3



Catalogue
FOOD SERVICE

Capitolo
COOKING

Modelo
MCIE-500 M 50-60 Hz 380-400V 3N

19084231

16/11/2021

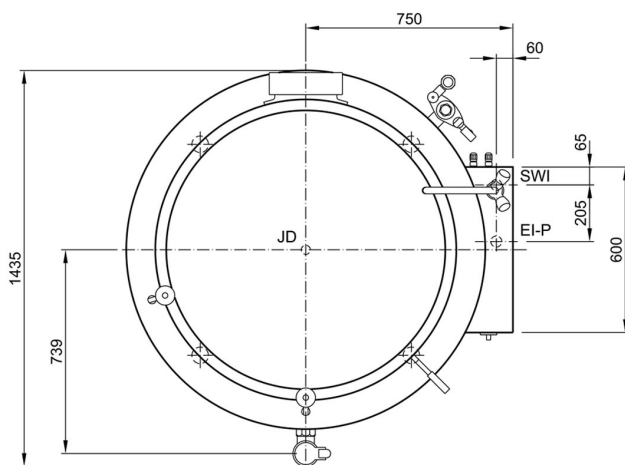
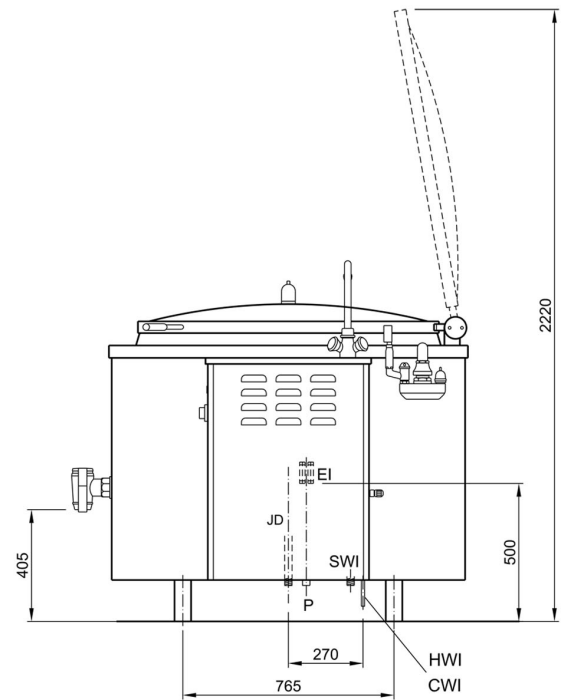
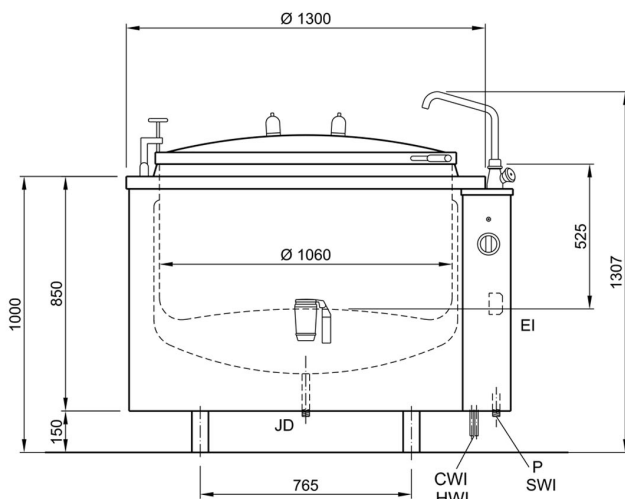

ALLACCIAMENTI - BRANCHEMENTS - CONNECTIONS

HWI -	ACQUA CALDA EAU CHAUDE HOT WATER	100 - 250 kPa (1 - 2,5 bar)	1/2" F
CWI -	ACQUA FREDDA EAU FROIDE COLD WATER	100 - 250 kPa (1 - 2,5 bar)	1/2" F
SWI -	ACQUA ADDOLCITA - OPZIONALE EAU DEMINERALISE - OPTIONAL SOFTENED WATER - OPTIONAL	100 - 250 kPa (1 - 2,5 bar)	3/4" M
JD -	SCARICO INTERCAPEDINE VIDANGE CHEMISE JACKET DRAIN		1/2" M
EI -	CAVO ELETTRICO CABLE ELECTRIQUE ELECTRIC CABLE	STANDARD - 380-415V 3N 50-60Hz OPTIONAL - 380-415V 3 50-60Hz	48kW 48kW
P -	PASSACAVO PRESSE ETOUPE CABLE GLAND	OPTIONAL - 220-240V 3 50-60Hz	48kW