



Catalogue
FOOD SERVICE
Chapter
COOKING

Specific model
MCG-500 LPG 50-60 Hz 220-230V 3N

19001445

16/11/2021

DENOMINATION:

Cylindrical boiling pan directly heated with gas 500 L

DESCRIPTION :

- Boiling pan with cylindrical structure and recipient, suitable for placement in transit areas with reduced dimensions where appliances with sharp edges and surfaces may cause ergonomic and movement problems, allowing it to be used comfortably from different angles.
- Well with AISI-316 stainless steel bottom with a thickness of between 20/10 and 40/10, suitable for products that are particularly acidic.
- AISI-304 stainless steel walls with a thickness of between 20/10 and 40/10.
- Double wall in indirect versions.
- AISI-304 stainless steel cover with a thickness of 15/10, balance springs and an athermic handle.
- Supporting structure in AISI-304 stainless steel.
- Satin AISI-304 exterior coating.
- Adjustable stainless-steel feet.
- Heat insulation guaranteed by high-density ceramic fibre plates.
- Tank drainage hole with a removable filter.
- Front drainage tap with an insulated athermic handle.
- Gauge for controlling pressure inside the double wall.
- Manual valve for emptying air in order to depressurise the chamber during heating.
- Water is added to the well through a tap with a moveable outlet.
- "- High-performance stainless-steel tubular burners.
- Manual piezoelectric ignition and pilot flame.
- Smoke extraction grille.
- Tap with safety valve and thermocouples (direct version)."

POSSIBLE ACCESSORIES :

- ACCESSORIES LARGE CAP.

DIMENSIONS

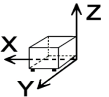

X Width	1390 mm	X Gross width	1490 mm
Y Depth	1479 mm	Y Gross depth	1490 mm
Z Height	1020 mm	Z Gross height	1410 mm
Net Weight	245,0 kg	Gross Weight	303,0 kg
Net volume	1,690 m3	Gross volume	3,130 m3

ELECTRICITY TECHNICAL SPECIFICATIONS

Voltage	230V - 1N
Electric frequency	50Hz

GAS TECHNICAL SPECIFICATIONS

Gas type	LPG
Gas power	55,00 kW
Gas consumption	4,620 kg/h

CONNECTIONS TECHNICAL SPECIFICATIONS

Gas diameter 1	R 3/4"
Water inlet diameter	R=1/2"



Catalogue
FOOD SERVICE

Capitolo
COOKING

Modelo
MCG-500 LPG 50-60 Hz 220-230V 3N

19001445

16/11/2021

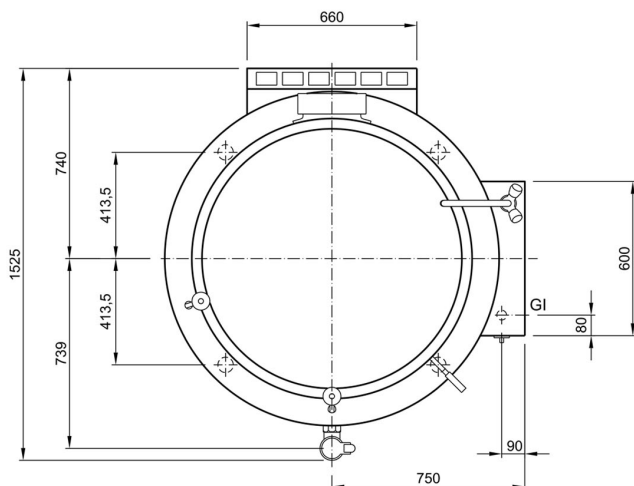
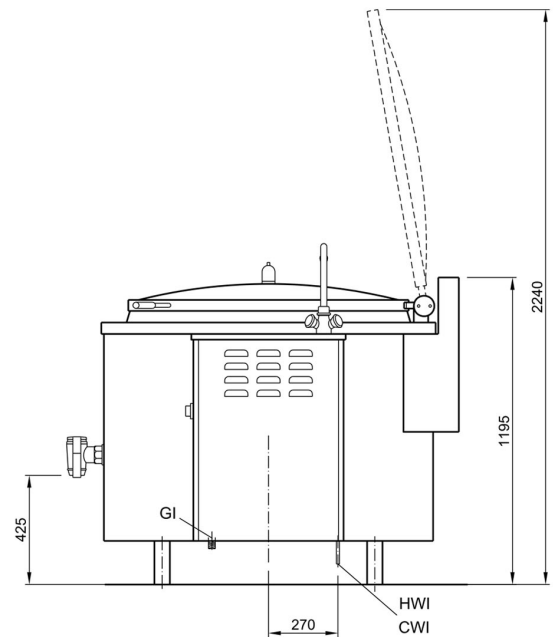
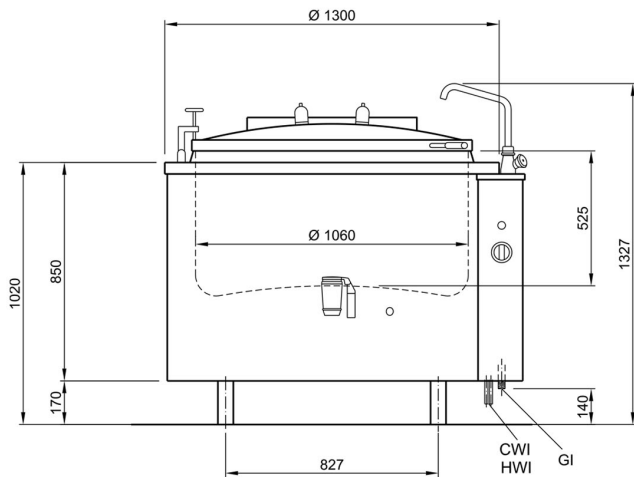

ALLACCIAMENTI - BRANCHEMENTS - CONNECTIONS - ANSCHLUSSE

HWI -	ACQUA CALDA EAU CHAUDE HOT WATER	100 - 250 kPa (1 - 2,5 bar)	1/2" F
CWI -	ACQUA FREDDA EAU FROIDE COLD WATER	100 - 250 kPa (1 - 2,5 bar)	1/2" F
GI -	ARRIVO GAS ENTREE GAZ GAS INLET	55 KW	1/2" ISO 7/1 R1