



Catalogue
FOOD SERVICE
Chapter
COOKING

Specific model
FT-G710 C L+R NG

19101403

23/10/2024

DENOMINATION:

GN gas frytop with thermostatic temperature control, chrome surface 2/3 smooth and 1/3 ribbed hot-plate, 1 module, 700 range.

DESCRIPTION :

- Stamped surface tops manufactured in 1.5 mm thick AISI-304 stainless steel.
- Laser-cut joints, automatic welding and polishing. Hidden screws.
- Rapid reaction and recovery times of the fry-top temperature.
- The fry tops are welded to the stamped surface top.
- The stamped shell and its rounded edges and corners make cleaning much easier.
- The fry top is tilted towards the front to make it easier to collect grease and liquids.
- Fitted with an opening to collect cooking grease and a tray to store it which has capacity to store up to 2 litres depending on the model.
- Optional anti-splash side and rear guards, easy to remove.
- High-temperature enamelled cast iron flue protector.
- Access to components from the front.
- Machines with IPX5 grade water protection.
- "
- Model with mixed hot plates (2/3 smooth + 1/3 grooved).
- "- 15 mm thick mild steel fry tops which are quick-heating and high power.
- Version with 50-micron thick chrome surface for the three hot plate types."
- "- Gas heated model with high efficiency burners (separate burners for whole-module models).
- Model with thermostatic temperature control (between 100 and 300 °C).
- Burner ignition through electronic spark igniter. Therefore, the gas models do not need electricity for installation. With an access tube for manual ignition.
- "
- Whole-module fry tops have two separate heating areas.

POSSIBLE ACCESSORIES :

- FRY-TOP ACCESSORIES KORE
- ACCESSORIES KORE
- STANDS 700

SUPPLIED ACCESSORIES:

- 19045082 Fry-top guard 1M for Kore 900 1

DIMENSIONS

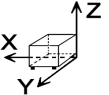

X Width	800 mm	X Gross width	840 mm
Y Depth	730 mm	Y Gross depth	822 mm
Z Height	290 mm	Z Gross height	535 mm
Net Weight	128,0 kg	Gross Weight	146,0 kg
Net volume	0,170 m3	Gross volume	0,369 m3

ELECTRICITY TECHNICAL SPECIFICATIONS

Voltage	N/A
Phases	N/A

GAS TECHNICAL SPECIFICATIONS

Gas power	15,00 kW
Gas consumption	1,588 m3/h
Regulated	LPG G30/G31 28-30/37 mbar NG G20/G25/G25.1 20/25/25 mbar

CONNECTIONS TECHNICAL SPECIFICATIONS

Gas diameter 1	R.3/4"G
----------------	---------



Catalogue
FOOD SERVICE
Chapter
COOKING

Specific model
FT-G710 C L+R NG

19101403

23/10/2024

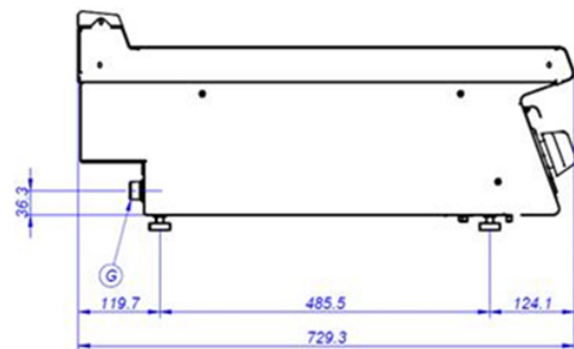
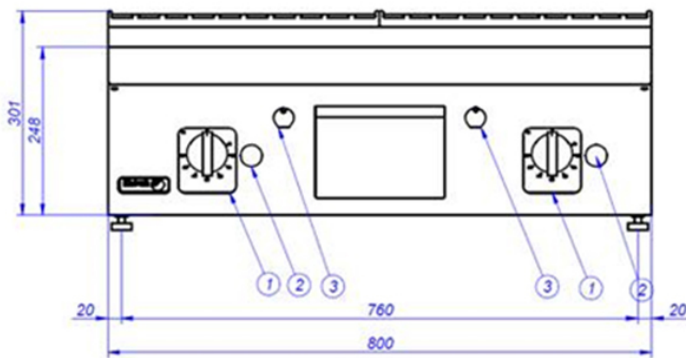

- | | | |
|----|------------------------------|-----------------------|
| G. | Entrada de Gas | Gas Inlet |
| E. | Conexión eléctrica | Electrical connection |
| 1. | Válvula de gas | Gas valve |
| 2. | Pulsador tren de chispas | Piezoelectric ignitor |
| 3. | Orificio de encendido manual | Manual ignition hole |