



Catalogue
FOOD SERVICE
Chapter
COOKING

Specific model
C-G720 H NG

19074760

04/09/2023

DENOMINATION:

Countertop gas cookers GN. 2 burners, high power. 700 range.

DESCRIPTION :

- "- Stamped surface tops manufactured in 1.5 mm thick AISI-304 stainless steel.
- Laser-cut joints and automatic welding. Hidden screws.
- 397 x 580 mm double grates (397 x 290 mm for each burner) enabling the use of large pots and pans. The reduced distance of 75 mm between the central bars makes it possible to use pots with a very small diameter (8 cm), avoiding the risk of smaller pans tipping over.
- The grates are made of RAAF enamelled cast iron (resistant to alkaline and acid products, fire and high temperatures).
- Double-crown burners and diffusers made of nickel-plated cast iron which guarantee an even distribution of heat from the flame to the base of the pans, even for large pans. This therefore prevents heat from building up in a specific point and optimises energy transfer to the product.
- Burners of different strengths to adapt to containers and for use with different foods:
 - 5.25 kW (Ø 100 mm),
 - 8.0 kW (Ø 120 mm),
- Burners are easy to position.
- Low-consumption pilot light and thermocouple located within the body of the burner for greater protection.
- Flexible stainless-steel gas pipes, facilitating internal manipulations in order to make repairs easier.
- Controls with a protective support base and system to prevent water infiltration.
- High-temperature enamelled cast iron flue protector which is flush with the grates therefore improving manoeuvrability, supporting larger containers and increasing the usable surface area.
- Access to components from the front."

POSSIBLE OPTIONS :

- Wheels Kit (Factory Assembly)

POSSIBLE ACCESSORIES :

- ACCESSORIES KORE
- STANDS 700
- COOKER ACCESSORIES KORE
- TALL CHIMNEY KORE

DIMENSIONS

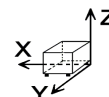

| | | | |
|------------|----------|----------------|----------|
| X Width | 400 mm | X Gross width | 440 mm |
| Y Depth | 730 mm | Y Gross depth | 822 mm |
| Z Height | 290 mm | Z Gross height | 535 mm |
| Net Weight | 30,0 kg | Gross Weight | 43,0 kg |
| Net volume | 0,080 m3 | Gross volume | 0,193 m3 |

ELECTRICITY TECHNICAL SPECIFICATIONS

Voltage N/A - N/A

GAS TECHNICAL SPECIFICATIONS

Gas type NG
 Gas power 16,00 kW
 Gas consumption 1,460 m3/h
 Regulated LPG G30/G31 28-30/37 mbar
 NG G20/G25/G25.1 20/25/25 mbar

CONNECTIONS TECHNICAL SPECIFICATIONS

Gas diameter 1 R.3/4"G



Catalogue
FOOD SERVICE
Chapter
COOKING

Specific model
C-G720 H NG

19074760

04/09/2023

C-G720 & C-G720 H

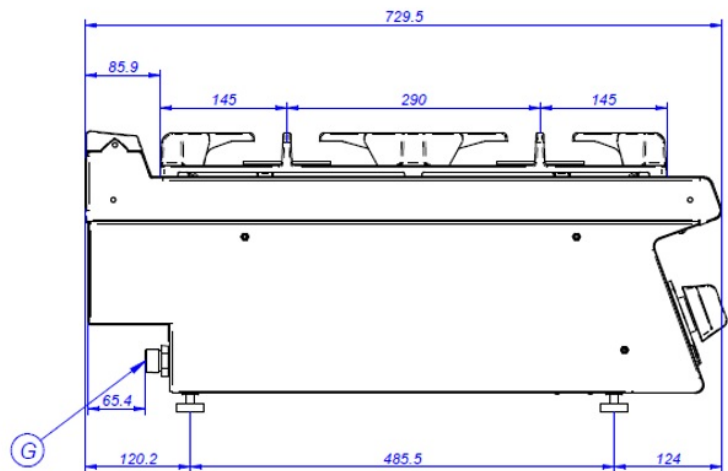
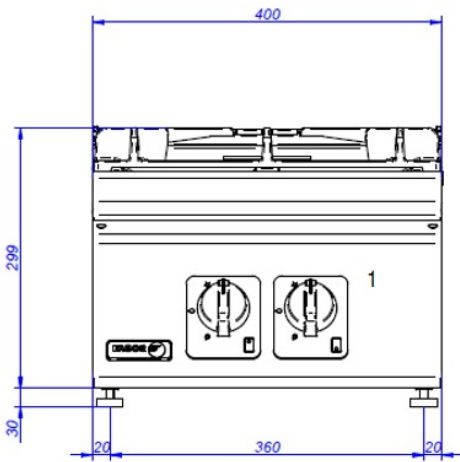

G. Entrada de Gas
1. Válvula de gas

Gas Inlet
Gas valve