



Catalogue
FOOD SERVICE
Chapter
COOKING

Specific model
MCIG-200 LPG 50-60 Hz 220-230V 3N

19003078

16/11/2021

DENOMINATION:

Cylindrical boiling pan indirectly heated with gas 200 L

DESCRIPTION :

- Boiling pan with cylindrical structure and recipient, suitable for placement in transit areas with reduced dimensions where appliances with sharp edges and surfaces may cause ergonomic and movement problems, allowing it to be used comfortably from different angles.
- Well with AISI-316 stainless steel bottom with a thickness of between 20/10 and 40/10, suitable for products that are particularly acidic.
- AISI-304 stainless steel walls with a thickness of between 20/10 and 40/10.
- Double wall in indirect versions.
- AISI-304 stainless steel cover with a thickness of 15/10, balance springs and an athermic handle.
- Supporting structure in AISI-304 stainless steel.
- Satin AISI-304 exterior coating.
- Adjustable stainless-steel feet.
- Heat insulation guaranteed by high-density ceramic fibre plates.
- Tank drainage hole with a removable filter.
- Front drainage tap with an insulated athermic handle.
- Gauge for controlling pressure inside the double wall.
- Manual valve for emptying air in order to depressurise the chamber during heating.
- Water is added to the well through a tap with a moveable outlet.
- "- Indirect heating equipment: pressure control in the double wall through a safety valve set to 0.5 bar, a manual depression valve and a gauge."

POSSIBLE ACCESSORIES :

- ACCESSORIES LARGE CAP.

DIMENSIONS

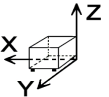

X Width	1090 mm	X Gross width	1160 mm
Y Depth	1195 mm	Y Gross depth	1190 mm
Z Height	900 mm	Z Gross height	1270 mm
Net Weight	174,0 kg	Gross Weight	205,0 kg
Net volume	1,000 m3	Gross volume	1,753 m3

ELECTRICITY TECHNICAL SPECIFICATIONS

Voltage	230V - 1N
Electric frequency	50Hz

GAS TECHNICAL SPECIFICATIONS

Gas type	LPG
Gas power	36,00 kW
Gas consumption	2,290 kg/h

CONNECTIONS TECHNICAL SPECIFICATIONS

Gas diameter 1	R 3/4"
Water inlet diameter	R=1/2"



Catalogue
FOOD SERVICE

Capitolo
COOKING

Modelo
MCIG-200 LPG 50-60 Hz 220-230V 3N

19003078

16/11/2021

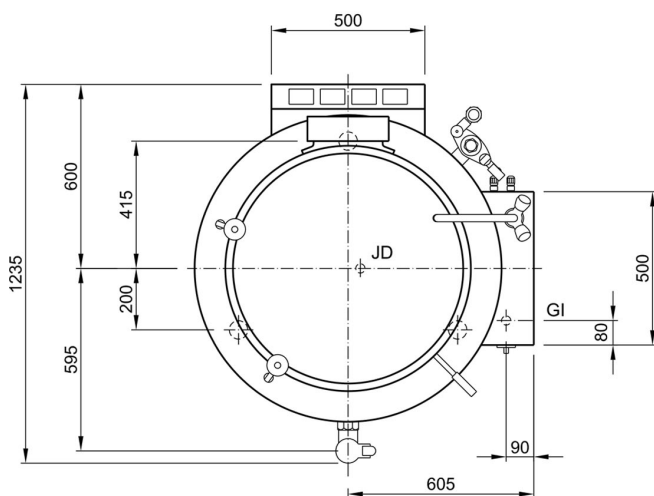
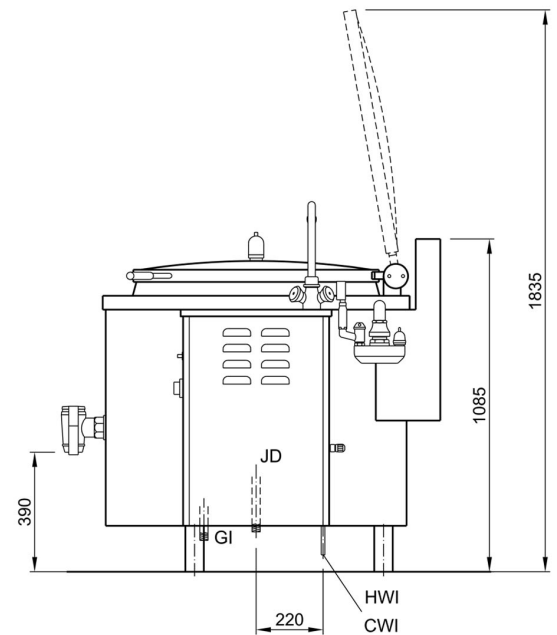
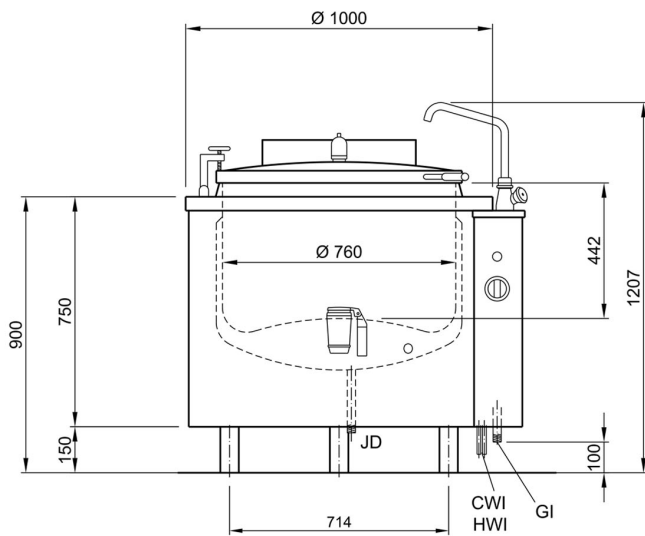

ALLACCIAMENTI - BRANCHEMENTS - CONNECTIONS - ANSCHLUSSE

HWI -	ACQUA CALDA EAU CHAUDE HOT WATER	100 - 250 kPa (1 - 2,5 bar)	1/2" F
CWI -	ACQUA FREDDA EAU FROIDE COLD WATER	100 - 250 kPa (1 - 2,5 bar)	1/2" F
JD -	SCARICO INTERCAPEDINE VIDANGE CHEMISE JACKET DRAIN		1/2" M
GI -	ARRIVO GAS ENTREE GAZ GAS INLET	39 KW	1/2" ISO 7/1 R1