



**Catalogue**  
FOOD SERVICE  
**Chapter**  
COOKING

**Specific model**  
B-E9051 I 400V 3N

19075417

11/11/2021

**DENOMINATION:**

Electric grill, stainless steel grill, half module, 900 range.

**DESCRIPTION :**

- Surface tops manufactured in 2 mm thick AISI-304 stainless steel.
- Laser-cut joints, automatic welding and polishes. Screws hidden from view.
- Grills fitted with 130 mm high dismantlable guard to avoid splashing, manufactured in stainless steel.
- High temperature enamelled cast iron flue protector.
- Access to the components from the front.
- Machines with IPX5 grade water protection.
- In the models with stainless steel grill, this is manufactured with sheets of AISI-304 in "V" shape to facilitate cleaning.
- The grills reach a very high temperature (400 °C), meaning that the surface of the product seals rapidly, keeping the inside of the food much juicier.
- Groups of three stainless steel elements under the roasting rack, with radiant deflector (a group of three elements for half-sized module models, two groups for whole module models).
- Independent control for each group of elements via an energy regulator.

**POSSIBLE OPTIONS :**

- 230 1N- Transformation A 230 V single phase
- 230 III - A 230 V three-phase transformation without neutral
- MARINE - Other machines - Ship transformation - 440 III

**POSSIBLE ACCESSORIES :**

- ACCESSORIES FOR CHARCOALS KORE
- KORE WHEELS
- TALL CHIMNEY KORE

**SUPPLIED ACCESSORIES:**

- 19058313 Scraper for charcoal with stainless steel grill Kore generation 1

**DIMENSIONS**

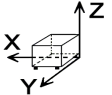

X Width	400 mm	X Gross width	440 mm
Y Depth	930 mm	Y Gross depth	1022 mm
Z Height	850 mm	Z Gross height	1255 mm
Net Weight	52,0 kg	Gross Weight	65,0 kg
Net volume	0,320 m3	Gross volume	0,564 m3

**ELECTRICITY TECHNICAL SPECIFICATIONS**

Electric power	7,500 kW
Amperage (A)	16A
Heating power	7,50 kW
Voltage	400V - 3N
Electric frequency	50/60Hz

**CONNECTIONS TECHNICAL SPECIFICATIONS**

230 V three-phase wiring	3X4MM2+T
Single-phase 230V wiring	2X10MM2+T
Three-phase +N 400V wiring	4X1,5MM2+T

Catalogue  
**FOOD SERVICE**

Capítulo  
**COOKING**

Modelo  
**B-E9051 I 400V 3N**

19075417

11/11/2021



**B-E9051**

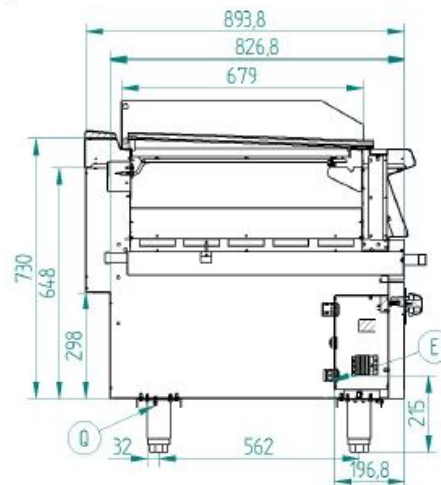
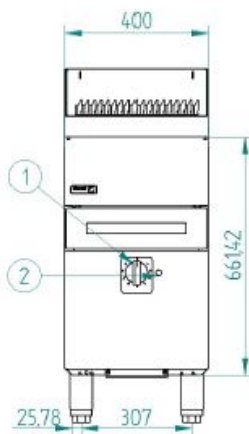

**B-E9101**

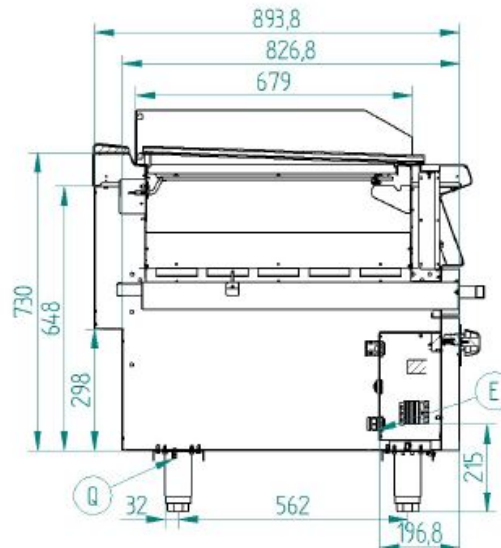
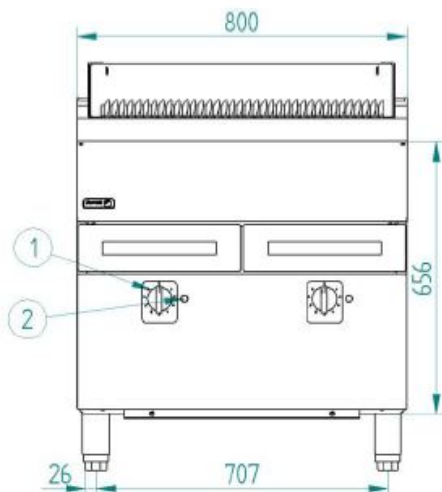

E – Conexión eléctrica  
Q – Conexión equipotencial  
1 – Mando eléctrico  
2 – Piloto ambar

Electrical connection  
Equipotential  
Electric control  
Ambar pilot