

# premium Charcoal oven90

pujadas®  
grill

 80 – 90  
diners



- Designed and manufactured entirely by Pujadas in high quality stainless steel.
- Perfect for indoor, open or outdoor kitchens.
- Thermally insulated body for greater efficiency and better protection from the outside.
- Upper and lower airflow regulators ensure easy temperature control.
- Double security firewalls for increased safety.
- Sunken charcoal fire bowl offers more space and easier operation.
- Adjustable grill height allows impressive versatility.

#### Available colors:



#### Each charcoal oven comes with:

- 1 Stainless steel tong
- 1 collect ashes shovel
- 1 Oven poker
- 1 Metallic brush

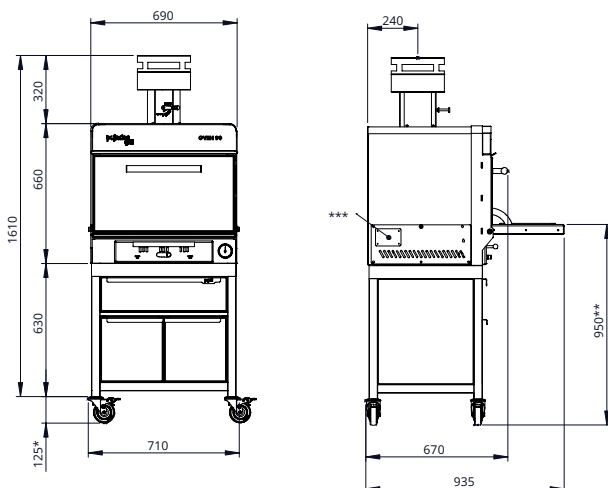

Ignition Time <sup>1</sup>	35 min aprox
Load of Marabú charcoal (Kg)	6-7
Daily Cons. of Marabú charcoal (Kg)	10
Charging autonomy <sup>2</sup>	9 - 10 hours
Recommended cooking temperature	250°C to 350°C
Production (Kg/h)	70 kg
Equivalent power (kW)	4
Extraction capacity (m <sup>3</sup> /h)	4070
Maximum flow (m <sup>3</sup> /h)	7.5

#### Measurements and weight without packaging

Oven	280 Kg	67 x 71 x 173.5
------	--------	-----------------

#### Measurements and weight with packaging

	Kg	cm W x D x H
Oven	240	78 x 75 x 108
Table	70	120 x 80 x 88

#### IMPORTANT!

- Installation on a steel table is recommended.
- Installation on wooden or ceramic worktops is not recommended.

\* Recommended table height to ensure the perfect use of the machine.

1. See instruction manual. 2. Depending on the use and quality of the charcoal, it may vary \* Indicative values