



# FOOD-PROCESSOR - EMULSIFIER KE-5V

Bowl capacity: 5.5 l. Adjustable speed with "brushless" technology.



DYNAMIC PREPARATION  
CUTTER-MIXERS & EMULSIFIERS

## SALES DESCRIPTION

- ✓ ULTRA Heavy Duty line. Adjustable speed motor block + 5.5 l cutter bowl with toothed blades and "cut&mix" scraper.
- ✓ To cut, grind, texturize, mix and knead any food in seconds.
- ✓ Ideal for emulsions and texturizations.
- ✓ Brushless technology: maximum efficiency.

### Equipped with "brushless" technology: powerful and efficient motors.

- ✓ Maximum efficiency: maintain the torque throughout the speed range.
- ✓ Exclusive "Force control system": guarantee of a uniform and high quality result.
- ✓ Lightweight and compact design: they weigh less, they occupy less space.
- ✓ Improved air/water-tightness since no ventilation is required.
- ✓ They generate less noise: improved workplace environment.

### Efficiency and performance

- ✓ Possibility of programming by time and pulse button.
- ✓ Reverse function, ideal for mixing products instead of cutting.
- ✓ 5.5 litre stainless steel hopper.
- ✓ Transparent lid with built-in "cut&mix" mixer.
- ✓ Depending on the purpose, the possibility of using optional smooth or perforated blades.
- ✓ Built-in parametrisable programs to obtain the desired texture in seconds and in a standardized way: dense texture, fine texture, pulses (PrecisePulse function).
- ✓ Option to customize programs for recipe standardization.

### Built to last

- ✓ Robust construction of stainless steel and food-grade materials of

- the highest quality: stainless steel motor block with aluminium lid.
- ✓ Stainless steel hopper with highly-resistant lid.

### Maximum comfort for the user

- ✓ Advanced control panel that is very intuitive to use and offers all the information at a glance.

### Maintenance, safety, hygiene

- ✓ Safety microswitches on the hopper and lid position.
- ✓ Appliance certified by NSF International (regulations on hygiene, cleaning and materials suitable for contact with foods).
- ✓ 100% tested.

## INCLUDES

- ✓ Set of serrated blades.
- ✓ "Cut&mix" scraper.

## OPTIONAL

- Smooth blades.
- Perforated blades.

## ACCESSORIES

- Blades for CK / K / KE
- "Cut&mix" scrapers CK / K / KE

## SPECIFICATIONS

Bowl capacity: 5.5 l  
 Bowl dimensions: Ø240 mm x 150 mm  
 Total loading: 1500 W  
 Speed, min-max: 300 rpm - 3000 rpm

### External dimensions (W x D x H)

- ✓ Width: 286 mm
  - ✓ Depth: 387 mm
  - ✓ Height: 487 mm
- Net weight: 18 kg

Crated dimensions  
 440 x 355 x 570 mm  
 Volume Packed: 0.09 m³  
 Gross weight: 23.5 kg

## AVAILABLE MODELS

1050834	Cutter-emulsifier KE-5V 230/50-60/1
1050836	Cutter-emulsifier KE-5V 120/50-60/1
1050842	Cutter-emulsifier KE-5V 230/50-60/1 K

\* Ask for special versions availability



product sheet  
updated 28/11/2024



# FOOD-PROCESSOR - EMULSIFIER KE-5V

Bowl capacity: 5.5 l. Adjustable speed with "brushless" technology.



DYNAMIC PREPARATION  
CUTTER-MIXERS & EMULSIFIERS

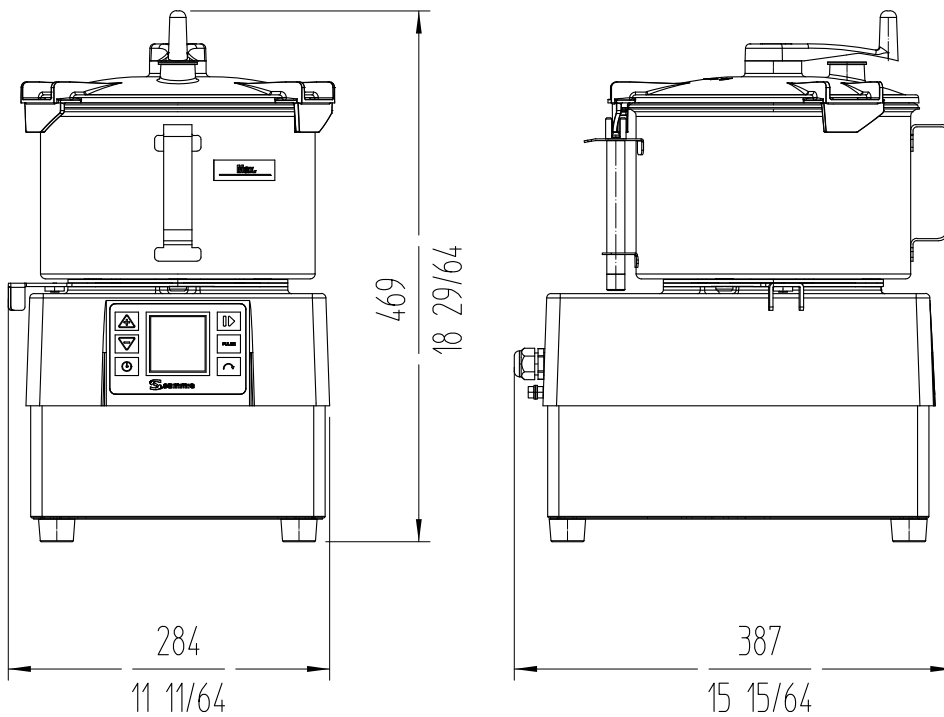

**sammic** | [www.sammic.com](http://www.sammic.com)  
Food Service Equipment Manufacturer

Polígono Basarte, 1. phone +34 943 15 72 36  
20720 Azkoitia, Spain [sales@sammic.com](mailto:sales@sammic.com)



Project	Date
Item	Qty
Approved	

product sheet  
updated 28/11/2024