



POTATO PEELER PP-12+

Output: 12 kg per cycle.



- ✓ Width with stand: 411 mm
 - ✓ Depth with stand: 700 mm
 - ✓ Height with stand: 1090 mm
- Net weight: 38 kg

Noise level (1m.): 70 dB(A)
Background noise: 32 dB(A)

AVAILABLE MODELS

1000420 Potato peeler PP-12+ 230-400/50/3 · 370 W

1000421 Potato peeler PP-12+ 230/50/1 · 400 W

1000422 Potato peeler PP-12+ 220-380/60/3

1000423 Potato peeler PP-12+ 220/60/1

1000426 Potato peeler PP-12+ 440/60/3

1000427 Potato peeler PP-12+ 120/60/1

* Ask for special versions availability

SALES DESCRIPTION

Aluminium made potato peeler.

Aluminium body potato peeler. Abrasive peeling. The abrasive is highly resistant and long lasting.

- ✓ Base Plate and chamber walls lined with abrasive.
- ✓ Aluminium body.
- ✓ Directable cylinder.
- ✓ Integral control panel complete with on/off push buttons and a 0-6 minute timer.

OPTIONAL

- Stainless steel floor stand.
- Water inlet kit (2003971).
- Filter with no-foam feature.

ACCESSORIES

- Stands for potato peelers PP / PPC
- Filters for potato peelers PP / PPC

SPECIFICATIONS

Hourly production: 220 kg / 300 kg

Capacity per load: 12 kg

Timer (min-max): 0' - 6'

Plate speed: 317 rpm

Total loading: 400 W (1~) / 370 W (3~)

External dimensions (W x D x H)

- ✓ Width: 395 mm
- ✓ Depth: 700 mm
- ✓ Height: 517 mm

External dimensions with stand



DYNAMIC PREPARATION
COMMERCIAL POTATO PEELERS

product sheet
updated 10/12/2024



POTATO PEELER PP-12+

Output: 12 kg per cycle.



DYNAMIC PREPARATION
COMMERCIAL POTATO PEELERS

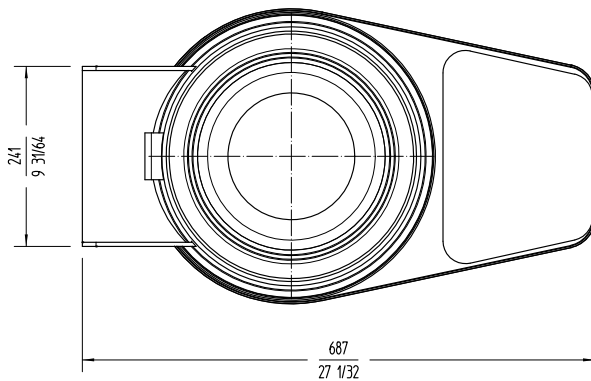
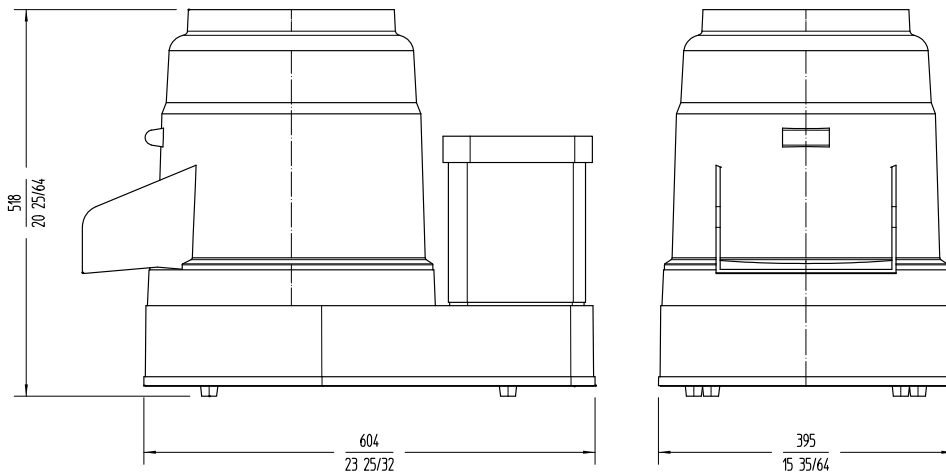

sammic | www.sammic.com
Food Service Equipment Manufacturer

Polígono Basarte, 1. phone +34 943 15 72 36
20720 Azkoitia, Spain sales@sammic.com



Project	Date
Item	Qty
Approved	

product sheet
updated 10/12/2024